



Agregaty skraplające OPTYMA™ R404A/R507, R134a, R407C

Agregaty skraplające OPTYMA™ R404A/R507

Agregat na czynnik R404A jest powszechnie używany na rynku chłodniczym, przeznaczony jest do zastosowań w niskich i średnich temperaturach, takich jak schładzanie produktów mleczarskich i nabiału oraz przechowywanie świeżej żywności, a także do głębokiego zamrażania produktów czy przechowywania lodów.



Lada chłodnicza



Zamrażarka do lodów

Agregaty skraplające OPTYMA™ R134a

Agregat na czynnik R134a jest przeznaczony do zastosowań w średnich temperaturach parowania, w urządzeniach takich jak przeszklone lada chłodnicze, schładzarki do napojów, a także w konkretnych niekomercyjnych zastosowaniach, na przykład w osuszaczach powietrza, gdzie wymagana jest praca w wysokich temperaturach i przy wysokiej temperaturze parowania.



Chłodziarka do napojów



Osuszacz powietrza

Agregaty skraplające OPTYMA™ R407C

Agregat na czynnik R407C świetnie sprawdza się w zastosowaniach w średnich temperaturach parowania, na przykład w układach klimatyzacyjnych.





Klimatyzacja w niewielkich sklepach



Domowe układy klimatyzujące

Agregaty skraplające OPTYMA™ R404A/R507 LBP

	Warunki testowe	Typ agregatu	Platforma	Wersja				Kod zasilania	HP	Skraplacz			Wentylator-skraplacz Łopátka wentylatora Ø [mm]	Wydajność w [W] przy temp.				
				A00	A01	A02	A04			Typ	Przepływ powietrza [m³/h]	Obj. wewn. [dm³]		-45	-40	-35	-30	-25
	CECOMAF	OP-LCHC004	TL	114X1208	114X1209		114X1211	G	¼	BG2	231	0.25	1 × 200	64	85	110	141	177
		OP-LCHC006	FR	114X1216	114X1217		114X1219	G	½	BG2	231	0.25	1 × 200	91	128	171	219	273
		OP-LCHC008	FR	114X1324	114X1325		114X1327	G	½	BG3	518	0.31	1 × 230	130	161	208	268	340
		OP-LCHC007	NL	114X1328	114X1329		114X1331	G	½	BG3	518	0.31	1 × 230	126	175	234	302	380
		OP-LCHC010	SC	114X1332	114X1333		114X1335	G	½	BG3	518	0.31	1 × 230			216	300	393
		OP-LCHC012	SC	114X1440	114X1441		114X1443	G	½	BG4	631	0.40	1 × 254	129	220	320	429	547
		OP-LCHC015	SC	114X1548	114X1549		114X1551	G	¾	BG5	583	0.53	1 × 254	198	292	400	521	654
		OP-LCHC018	SC	114X1556	114X1557		114X1559	G	¾	BG5	583	0.53	1 × 254	232	349	475	610	751
OP-LCHC021	SC	114X1564	114X1565		114X1567	G	¾	BG5	583	0.53	1 × 254	291	405	535	680	840		
OP-LCHC026	GS	114X1672	114X1673		114X1675	G	1	BG6	1150	0.63	1 × 300	350	500	670	860	1.070		
OP-LCHC034	GS	114X1780	114X1781		114X1783	G	1½	BG7	990	0.84	1 × 300	450	650	850	1.100	1.350		
	RGT20	OP-LCHC048	NT			114X5044		G	2½	A4	1.200	1.2	1 × 300	513	831	1.186	1.388	1.775
					114X5030		D											
					114X5037		E											
		OP-LCHC068	NT			114X5045		G	3½	C4	2.150	2.3	1 × 350	730	1.121	1.629	2.193	2.834
					114X5031		D											
				114X5038		E												
		OP-LCHC096	NT			114X5032		D	5	D4	2.000	3.1	1 × 350		1.474	2.083	2.771	3.567
					114X5039		E											
		OP-LCHC108	NT			114X5033		D	5½	E4	3.150	2.5	1 × 400		1.630	2.390	3.332	4.297
					114X5040		E											
		OP-LCHC136	NT			114X5034		D	7	G4	3.150	4.1	1 × 400		2.375	3.222	4.307	5.437
		114X5041			E													
OP-LCHC215	NT			114X5035		D	10	J4	6.000	4.4	1 × 500	2.407	3.565	4.910	6.588	8.308		
			114X5042		E													
OP-LCHC271	NT			114X5036		D	13	L4	5.850	6.3	1 × 500	3.488	4.988	6.726	8.901	11.092		
			114X5043		E													
OP-LGHC048	NT			114X5096		G	2½	C3	1.450	1.6	2 × 254	509	828	1.185	1.389	1.780		
			114X5089		E													
OP-LGHC068	NT			114X5097		G	3½	D3	2.800	1.5	2 × 300	711	1.096	1.595	2.147	2.773		
				114X5083		D												
		114X5090		E														
OP-LGHC096	NT			114X5084		D	5	E3	2.100	2.2	2 × 300		1.485	2.103	2.806	3.622		
				114X5091		E												
OP-LGHC108	NT			114X5085		D	5½	G3	4.600	2.3	2 × 355		1.605	2.345	3.253	4.172		
				114X5092		E												
OP-LGHC136	NT			114X5086		D	7	H3	3.600	4.7	2 × 355		2.449	3.415	4.472	5.678		
				114X5093		E												
OP-LGHC215	NT			114X5087		D	10	L3	9.000	5.1	2 × 450	2.396	3.551	4.891	6.563	8.274		
				114X5094		E												
OP-LGHC271	NT			114X5088		D	13	L3	8600	5.1	2 × 450	3.553	5.098	6.897	9.169	11.492		
				114X5095		E												

Warunki testowe

EN 13215

Temperatura otoczenia

Temperatura gazu na ssaniu

RGT 20

Stała temp. gazu na ssaniu

32°C

20°C

 = 10K przegrzanie

CECOMAF

Domowe i podobne

32°C

32°C

Wersja

A00 Bez zaworów i zbiornika do rurki kapilarnej

A01 Ze zbiornikiem, 2 zaworami odcinającymi, miedzianymi przyłączami i uchwytem do KP

A02 Ze zbiornikiem, 2 zaworami odcinającymi, z uniwersalnym odblokowaniem przełączanym (KP17WB), elastycznymi wężami i skrzynką elektryczną

A04 A01 + KP 17WB + zestaw FSA + przewód zasilający (bez UCGC034)

Dane elektryczne

Model	Sprężarka LRA [A]		Sprężarka MCC [A]						Wentylator MCC [A]	
	400 V/ 3 fazy	230 V/ 1 faza	400 V/ 3 fazy	Stycznik	Przełącznik nadmiarowy	230 V/ 1 faza	Stycznik	Przełącznik nadmiarowy	400 V/ 3 fazy	230 V/ 1 faza
OP-LCHC004	-	5.7	-	-	-	-	-	-	-	0.19
OP-LCHC006	-	9	-	-	-	-	-	-	-	0.19
OP-LCHC008	-	10	-	-	-	-	-	-	-	0.25
OP-LCHC007	-	10.4	-	-	-	-	-	-	-	0.25
OP-LCHC010	-	14.8	-	-	-	-	-	-	-	0.25
OP-LCHC012	-	18.6	-	-	-	-	-	-	-	0.39
OP-LCHC015	-	21.8	-	-	-	-	-	-	-	0.39
OP-LCHC018	-	23.5	-	-	-	-	-	-	-	0.39
OP-LCHC021	-	23.4	-	-	-	-	-	-	-	0.39
OP-LCHC026	-	25.7	-	-	-	-	-	-	-	0.75
OP-LCHC034	-	26.6	-	-	-	-	-	-	-	0.75
OP-LCHC048	16	37	4.8	CI 6	TI 16C	11	CI 12	TI 16C	0.35	0.85
OP-LCHC068	25	53	8.4	CI 9	TI 16C	17	CI 15	TI 16C	0.5	1.2
OP-LCHC096	32	-	10.1	CI 12	TI 16C	-	-	-	0.5	1.2
OP-LCHC108	45	-	12.1	CI 12	TI 16C	-	-	-	0.7	1.3
OP-LCHC136	51	-	14.3	CI 15	TI 16C	-	-	-	0.7	1.3
OP-LCHC215	74	-	22.3	CI 25	TI 25C	-	-	-	1.2	3.4
OP-LCHC271	96	-	27	CI 30	TI 30C	-	-	-	1.2	3.4
OP-LGHC048	16	-	4.8	CI 6	TI 16C	11	CI 12	TI 16C	-	2x0.32
OP-LGHC068	25	-	8.4	CI 9	TI 16C	17	CI 20	TI 25C	2x0.35	2x0.85
OP-LGHC096	32	-	10.1	CI 12	TI 16C	-	-	-	2x0.35	2x0.85
OP-LGHC108	45	-	12.1	CI 12	TI 16C	-	-	-	2x0.5	2x1.2
OP-LGHC136	51	-	14.3	CI 15	TI 16C	-	-	-	2x0.5	2x1.2
OP-LGHC215	74	-	22.3	CI 25	TI 25C	-	-	-	2x1.2	2x1.7
OP-LGHC271	96	-	27	CI 30	TI 30C	-	-	-	2x1.2	2x1.7

parowania [°C]				Obszar zastosowań w temp. otoczenia	Pobór mocy [W] przy temp. parow.		Pojem. zbiornika [l]	Wymiary [mm]						Waga [kg]				Typ sprężarki		
					-25°C	-35°C		Rys.	Wys. H [mm]	Szer. W [mm]	Łdugość D [mm]	Odległ. a [mm]	Odległ. b [mm]	linia ssawna	linia cieczowa	A00	A01		A02	A04
-20	-15	-10	-5																	
218	265	318	378	38°C: -45°C do -5°C	162		0.8	1	226	304	432	310		10 mm	6 mm	12.0	13.8		17.8	TL4CLX
332	397	468	542	38°C: -45°C do -10°C	267		0.8	2	226	304	432	310		10 mm	6 mm	15.1	16.7		17.8	FR6CLX
420	508	599	692	38°C: -45°C do -10°C	336		1.1	2	256	321	444	325		10 mm	6 mm	15.5	17.9		18.9	FR8.5CLX
497	563	667	779	38°C: -45°C do -10°C	336		1.1	3	256	321	444	325		10 mm	6 mm	15.5	17.9		18.9	NL7CLX
496	609	730	860	38°C: -45°C do -10°C	373		1.1	4	256	321	444	325		10 mm	6 mm	15.5	17.9		18.9	SC10CLX
672	804	943	1.088	38°C: -45°C do -15°C	479		1.1	4	296	331	451	325		10 mm	6 mm	19.8	22.0		22.9	SC12CLX
799	955	1.122	1.298	38°C: -45°C do -10°C	558		1.1	4	296	331	473	325		10 mm	6 mm	21.1	23.4		24.2	SC15CLX
899	1.052	1.212	1.379	38°C: -45°C do -15°C	649		1.1	4	296	331	513	365		10 mm	6 mm	21.1	23.4		24.2	SC18CLX
1.014	1.202	1.407		38°C: -45°C do -15°C	754		1.1	4	296	331	513	365		10 mm	6 mm	21.1	23.4		24.2	SC21CLX
1.290	1.525	1.770		38°C: -45°C do -23.3°C	1.023		2.4	7	340	430	480	310	385	12 mm	10 mm	36	39		40.5	GS26CLX
1.625	1.900	2.200		38°C: -45°C do -23.3°C	1.170		2.4	7	340	430	480	310	385	12 mm	10 mm	39	42		43.5	GS34CLX
2.186	2.614	3.054		46°C: -20°C do -35°C 43°C: -15°C do -40°C	935		3	5	402	500	600	400	465	5/8"	3/8"			54		NTZ048
3.544	4.317	5.139			1.478		6	5	555	630	650	400	595	5/8"	1/2"			64		NTZ068
4.461	5.442	6.499			1.851		6	5	555	630	650	400	595	7/8"	1/2"			78		NTZ096
5.328	6.399	7.500			2.274		6	5	605	630	650	400	595	7/8"	1/2"			92		NTZ108
6.685	8.030	9.466			3.029		8	5	656	755	700	400	720	7/8"	1/2"			95		NTZ136
10.169	12.158	14.229			4.814		14	5	708	900	900	600	865	1 1/8"	5/8"			151		NTZ215
13.431	15.900	18.435			6.312		14	5	759	900	900	600	865	1 1/8"	5/8"			166		NTZ271
2.196	2.629	3.079			998		3	6	392	700	500	300	660	5/8"	3/8"			55		NTZ048
3.463	4.210	5.009			1.487		6	6	442	800	600	400	760	5/8"	1/2"			62		NTZ068
4.548	5.570	6.677			1.869		6	6	442	800	600	400	760	7/8"	1/2"			78		NTZ096
5.139	6.135	7.132			2.267		8	6	555	1000	700	460	960	7/8"	1/2"			102		NTZ108
7.020	8.496	10.080			3.130		8	6	555	1000	700	460	960	7/8"	1/2"			107		NTZ136
10.124	12.092	14.156			4.413		14	6	671	1200	800	500	1160	1 1/8"	5/8"			152		NTZ215
14.018	16.696	19.517			6.512		14	6	671	1200	800	500	1160	1 1/8"	5/8"			158		NTZ271

Kod zasilania

A Sprężarka 220 V/1 faza/50+60 Hz, wentylator 220 V/1 faza/50+60 Hz
D Sprężarka 400 V/3 fazy/50 Hz, wentylator 400 V/3 fazy/50 Hz

E Sprężarka 400 V/3 fazy/50 Hz, wentylator 230 V/1 faza/50 Hz
G Sprężarka 220 V/1 faza/50 Hz, wentylator 220 V/1 faza/50 Hz

Platforma GS: Dane wstępne**Dobór automatyki chłodniczej**

Model	Typ zaworu rozprężnego	Dysza		Typ filtra osuszacza	Typ wziernika	Typ presostatu	Typ termostatu	Typ zaworu elektromag. -25°C	Nr kodowy cewki	Typ reg. obrotów wentyl.	Typ obudowy agregatu
		-10°C	+5°C								
OP-LHC004	TS 2/TES 2	0X	0X	DML 032	SGN 6	KP 1/KP 7/KP 17	KP 61/EKC 202		018F6701		118U4620
OP-LHC006	TS 2/TES 2	0X	0X	DML 032	SGN 6	KP 1/KP 7/KP 17	KP 61/EKC 202		018F6701		118U4620
OP-LHC008	TS 2/TES 2	0X	00	DML 032	SGN 6	KP 1/KP 7/KP 17	KP 61/EKC 202		018F6701		118U4620
OP-LHC007	TS 2/TES 2	0X	00	DML 032	SGN 6	KP 1/KP 7/KP 17	KP 61/EKC 202		018F6701		118U4620
OP-LHC010	TS 2/TES 2	0X	00	DML 032	SGN 6	KP 1/KP 7/KP 17	KP 61/EKC 202		018F6701		118U4620
OP-LHC012	TS 2/TES 2	0X	01	DML 032	SGN 6	KP 1/KP 7/KP 17	KP 61/EKC 202		018F6701		118U4620
OP-LHC015	TS 2/TES 2	00	01	DML 032	SGN 6	KP 1/KP 7/KP 17	KP 61/EKC 202		018F6701		118U4620
OP-LHC018	TS 2/TES 2	00	01	DML 032	SGN 6	KP 1/KP 7/KP 17	KP 61/EKC 202		018F6701		118U4620
OP-LHC021	TS 2/TES 2	00	01	DML 032	SGN 6	KP 1/KP 7/KP 17	KP 61/EKC 202		018F6701		118U4621
OP-LHC026	TS 2/TES 2	00	01	DML 032	SGN 10	KP 1/KP 7/KP 17	KP 61/EKC 202		018F6701		118U4621
OP-LHC034	TS 2/TES 2	00	01	DML 032	SGN 10	KP 1/KP 7/KP 17	KP 61/EKC 202		018F6701		118U4621
OP-LHC048				DML 053	SGN 10	KP 1/KP 7/KP 17	KP 61/EKC 202	EVR 3	018F6701	RGE-Z1L4-7DS	118U8030
OP-LHC068				DML 084	SGN 12	KP 1/KP 7/KP 17	KP 61/EKC 202	EVR 3	018F6701	RGE-Z1L4-7DS	118U8031
OP-LHC096				DML 084	SGN 12	KP 1/KP 7/KP 17	KP 61/EKC 202	EVR 3	018F6701	RGE-Z1L4-7DS	118U8031
OP-LHC108				DML 084	SGN 12	KP 1/KP 7/KP 17	KP 61/EKC 202	EVR 3	018F6701	RGE-Z1L4-7DS	118U8031
OP-LHC136				DML 084	SGN 12	KP 1/KP 7/KP 17	KP 61/EKC 202	EVR 6	018F6701	RGE-Z1L4-7DS	118U8032
OP-LHC215				DML 165	SGN 16	KP 1/KP 7/KP 17	KP 61/EKC 202	EVR 6	018F6701	RGE-Z1N4-7DS	118U8033
OP-LHC271				DML 165	SGN 16	KP 1/KP 7/KP 17	KP 61/EKC 202	EVR 6	018F6701	RGE-Z1N4-7DS	118U8033
OP-LGHC048				DML 053	SGN 10	KP 1/KP 7/KP 17	KP 61/EKC 202	EVR 3	018F6701	RGE-Z1L4-7DS	7710017
OP-LGHC068				DML 084	SGN 12	KP 1/KP 7/KP 17	KP 61/EKC 202	EVR 3	018F6701	RGE-Z1L4-7DS	7710018
OP-LGHC096				DML 084	SGN 12	KP 1/KP 7/KP 17	KP 61/EKC 202	EVR 3	018F6701	RGE-Z1L4-7DS	7710018
OP-LGHC108				DML 084	SGN 12	KP 1/KP 7/KP 17	KP 61/EKC 202	EVR 3	018F6701	RGE-Z1L4-7DS	7710019
OP-LGHC136				DML 084	SGN 12	KP 1/KP 7/KP 17	KP 61/EKC 202	EVR 6	018F6701	RGE-Z1L4-7DS	7710019
OP-LGHC215				DML 165	SGN 16	KP 1/KP 7/KP 17	KP 61/EKC 202	EVR 6	018F6701	RGE-Z1N4-7DS	7710020
OP-LGHC271				DML 165	SGN 16	KP 1/KP 7/KP 17	KP 61/EKC 202	EVR 6	018F6701	RGE-Z1N4-7DS	7710020

Dobór uzależniony od zastosowania

Podane RGE dotyczą wyłącznie wentylatorów jednofazowych

Agregaty skraplające OPTYMA™ R404A/R507 MBP

	Warunki testowe	Typ agregatu	Platforma	Wersja				Kod zasilania	HP	Skraplacz			Wentylator-skraplacza	Wydajność w [W] przy temp.						
				A00	A01	A02	A04			Typ	Przepływ powietrza [m³/h]	Obj. wewn. [dm³]		Łopatka wentylatora Ø [mm]	-30	-25	-20	-15	-10	-5
	CECOMAF	OP-MCHC004	TL	114X2208	114X2209		114X2211	G	¼	BG2	231	0.25	1 × 200					265	314	377
		OP-MCHC006	FR	114X2316	114X2317		114X2319	G	½	BG3	518	0.31	1 × 230					428	511	603
		OP-MCHC007	NF	114X2424	114X2425		114X2427	G	½	BG4	631	0.40	1 × 254					577	688	810
		OP-MCHC010	SC	114X2532	114X2533		114X2535	A	½	BG5	583	0.53	1 × 254			604	736	884	1.046	
		OP-MCHC012	SC	114X2540	114X2541		114X2543	G	½	BG5	583	0.53	1 × 254			715	863	1.027	1.205	
		OP-MCHC015	SC	114X2648	114X2649		114X2651	G	½	BG6	1.132	1.1	1 × 300			893	1.081	1.290	1.519	
		OP-MCHC018	SC	114X2756	114X2757		114X2759	G	5/8	BG7	827	1.8	1 × 300			1.062	1.287	1.538	1.816	
		OP-MCHC021	GS	114X2764	114X2765		114X2767	G	7/8	BG7	990	0.84	1 × 300			1.165	1.410	1.665	1.925	
	RGT20	OP-MCHC026	GS	114X2772	114X2773		114X2775	G	1	BG7	990	0.84	1 × 300			1.275	1.575	1.870	2.175	
		OP-MCHC034	GS	114X2880	114X2881		114X2883	G	1½	BG8	2.300	1.36	1 × 350			1.900	2.350	2.800	3.250	
		OP-MCHC038	MP			114X5322		G	1¾	B4	1.750	1.3	1 × 350	1.216	1.582	2.012	2.501	3.045	3.636	
					114X5307		D													
					114X5312		E													
							114X5323		G	2	C4	2.150	2.3	1 × 350	1.662	2.187	2.782	3.440	4.149	4.905
					114X5308		D													
							114X5313		E	2½	C4	2.150	2.3	1 × 350	1.763	2.343	2.998	3.715	4.487	5.299
					114X5324		G													
					114X5309		D													
							114X5314		E	3	D4	2.000	3.1	1 × 350	2.036	2.675	3.391	4.173	5.010	5.884
					114X5325		G													
					114X5310		D	3½	E4	3.150	2.5	1 × 400	2.388	3.114	3.925	4.809	5.751	6.739		
			114X5315		E															
			114X5311		D															
					114X5316		E	4½	F4	3.300	3.1	1 × 400	2.231	3.054	4.020	5.119	6.349	7.692		
			114X5029		G															
			114X5006		D															
					114X5018		E	4¾	G4	3.150	4.1	1 × 400	2.316	3.222	4.291	5.520	6.900	8.423		
			114X5007		D															
					114X5019		E	5½	H4	4.300	4.1	1 × 500	2.914	3.969	5.215	6.653	8.277	10.080		
			114X5008		D															
					114X5020		E	6	J4	6.000	4.4	1 × 500	3.362	4.545	5.939	7.552	9.372	11.937		
			114X5009		D															
					114X5021		E	6½	K4	6.200	4.7	1 × 500	4.048	5.399	6.956	8.715	10.663	12.794		
			114X5010		D															
					114X5022		E	8½	L4	5.850	6.3	1 × 500	4.277	5.928	7.843	9.998	12.379	14.950		
			114X5011		D															
					114X5023		E	10	M4	11.000	7.4	2 × 500	6.040	8.107	10.539	13.348	16.512	20.030		
			114X5058		D															
					114X5073		E	12	M4	11.000	7.4	2 × 500	7.180	9.526	12.229	15.268	18.642	22.309		
			114X5059		D															
					114X5074		E	13½	N4	9.200	12.3	2 × 500	7.989	10.611	13.642	17.070	20.873	25.030		
			114X5060		D															
					114X5075		E													

Warunki testowe
EN 13215

Temperatura otoczenia 32°C
Temperatura gazu na ssaniu 20°C
Dochłodzenie w zakresie agregatu skraplającego

Przegrzanie 10K

RGT20
Stała temp. gazu na ssaniu 32°C
20°C

CECOMAF
Domowe i podobne 32°C

Dane elektryczne

Model	Sprężarka LRA [A]		Sprężarka MCC [A]						Wentylator MCC [A]	
	400 V/ 3 fazy	230 V/ 1 faza	400 V/ 3 fazy	Stycznik	Przełącznik nadmiarowy	230 V/ 1 faza	Stycznik	Przełącznik nadmiarowy	400 V/ 3 fazy	230 V/ 1 faza
OP-MCHC004	-	7.5	-	-	-	-	-	-	-	0.19
OP-MCHC006	-	10.9	-	-	-	-	-	-	-	0.25
OP-MCHC007	-	20.0	-	-	-	-	-	-	-	0.39
OP-MCHC010	-	18.4	-	-	-	-	-	-	-	0.39
OP-MCHC012	-	23.4	-	-	-	-	-	-	-	0.39
OP-MCHC015	-	23.4	-	-	-	-	-	-	-	0.48
OP-MCHC018	-	23.4	-	-	-	-	-	-	-	0.48
OP-MCHC021	-	24.4	-	-	-	-	-	-	-	0.75
OP-MCHC026	-	26.6	-	-	-	-	-	-	-	0.75
OP-MCHC034	-	27.2	-	-	-	-	-	-	-	0.62
OP-MCHC038	29.2	56	6.3	CI 9	TI 16C	15	CI 16	TI 16C	0.5	1.2
OP-MCHC048	29.2	56	6.3	CI 9	TI 16C	16	CI 16	TI 16C	0.5	1.2
OP-MCHC054	29.2	56	6.4	CI 9	TI 16C	20	CI 20	TI 25C	0.5	1.2
OP-MCHC060	38.1	61	8.5	CI 12	TI 16C	20	CI 20	TI 25C	0.5	1.2
OP-MCHC068	38.1	-	9	CI 12	TI 16C	-	-	-	0.7	1.3
OP-MCZC086	48.5	92	11.5	CI 15	TI 16C	29	-	TI 25C	0.7	1.3
OP-MCZC096	64	-	12	CI 15	TI 16C	-	-	-	0.7	1.3
OP-MCZC108	64	-	14	CI 15	TI 16C	-	-	-	1.2	3.4
OP-MCZC121	80	-	17	CI 20	TI 25C	-	-	-	1.2	3.4
OP-MCZC136	80	-	19	CI 20	TI 25C	-	-	-	1.2	3.4
OP-MCZC171	90	-	22	CI 25	TI 25C	-	-	-	1.2	3.4
OP-MGZC215	105	-	27	CI 37	TI 25C	-	-	-	2x1.2	2x3.4
OP-MGZC242	115	-	30	CI 37	TI 25C	-	-	-	2x1.2	2x3.4
OP-MGZC271	140	-	36	CI 45	TI 25C	-	-	-	2x1.2	2x3.4

parowania [°C]				Obszar zastosowań w temp. otoczenia	Pobór mocy [W] przy temp. parow.		Objem. zbiornika [l]	Wymiary [mm]								Waga [kg]				Typ sprężarki	
					-10°C	5°C		Rys.	Wys. H [mm]	Szer. W [mm]	Długość D [mm]	Odlegl. a [mm]	Odlegl. b [mm]	linia ssawna [mm]	linia cieczowa [mm]	A00	A01	A02	A04		
0	5	7.2	10																		
450	528	563	588	38°C: -15°C do +10°C		284	0.8	1	226	304	432	310		10 mm	6 mm	12.0	13.8		17.8	TL4DLX	
705	812	860	923	38°C: -15°C do 0°C		502	1.1	2	256	321	444	325		10 mm	6 mm	15.5	17.9		18.9	FR6DLX	
941	1.080	1.143		38°C: -15°C do 0°C		624	1.1	3	296	331	451	325		10 mm	6 mm	15.9	18.3		19.3	NF7MLX	
1.220	1.403	1.486		38°C: -15°C do -5°C		728	1.1	4	296	321	473	325		10 mm	6 mm	19.8	22.0		22.9	SC10MLX	
1.392	1.586			38°C: -15°C do -6.7°C		890	1.1	4	296	321	473	325		10 mm	6 mm	19.8	22.0		22.9	SC12MLX	
1.765	2.026	2.145		38°C: -15°C do -5°C		1.145	1.1	4	350	442	610	370		10 mm	6 mm	33.7	40.6		42.5	SC15MLX	
2.116	2.437	2.584		38°C: -15°C do -5°C		1.235	1.1	4	350	442	610	370		10 mm	6 mm	41.6	43.6		47.4	SC18MLX	
2.195	2.460	2.600		38°C: -25°C do -10°C		1.250	1.6	7	340	430	480	310	385	16 mm	10 mm	33.0	36.0		37.5	GS21MLX	
2.470	2.765	2.850		38°C: -20°C do -10°C		1.500	1.6	7	340	430	480	310	385	16 mm	10 mm	36.0	39.0		40.5	GS26MLX	
3.725	4.200	4.375		38°C: -20°C do -10°C		2.220	2.4	8	450	500	600	310	470	16 mm	10 mm	41.0	44.0		49.5	GS34MLX	
4.270	4.948	6.141	7.660	43°C: -30°C do 0°C 46°C: -25°C do -5°C	1.502		3	5	451	500	600	400	465	5/8"	3/8"				56		MPZ038
5.094	6.520	6.892	7.365		2.016		6	5	555	630	650	400	595	5/8"	1/2"				64		MPZ048
6.146	7.013	7.403	7.900		2.297		6	5	555	630	650	400	595	5/8"	1/2"				65		MPZ054
6.797	7.722	8.137	8.664		2.683		6	5	555	630	650	400	595	5/8"	1/2"				68		MPZ061
7.768	8.813	9.282	9.878		3.081		6	5	605	630	650	400	595	5/8"	1/2"				72		MPZ068
9.146	10.682	11.330	12.301		3.384		8	5	656	755	700	400	720	7/8"	1/2"				95		MTZ51
10.085	11.854	12.604	13.730		3.670		8	5	656	755	700	400	720	7/8"	1/2"				100		MTZ57
12.051	14.187	15.094	16.455		4.888		8	5	656	755	700	400	720	7/8"	1/2"				113		MTZ65
13.601	15.997	17.012	18.534		5.355		10	5	708	900	900	600	865	1 1/8"	1/2"				127		MTZ73
15.106	17.550	18.584	20.136		6.335		10	5	759	900	900	600	865	1 1/8"	1/2"				140		MTZ81
17.700	20.564	21.758	23.549		7.521		14	5	759	900	900	600	865	1 1/8"	5/8"				162		MTZ100
23.863	28.004	29.761	32.395		9.777		14	6	759	1350	820	550	1.315	1 1/8"	5/8"				191		MTZ125
26.266	30.429	32.179	34.805		11.240		14	6	759	1350	820	550	1.315	1 1/8"	5/8"				194		MTZ144
29.508	34.290	36.291	39.292		12.492		14	6	759	1350	820	550	1.315	1 1/8"	5/8"				199		MTZ160

Wersja

- A00 Bez zaworów i zbiornika do rurki kapilarnej
A01 Ze zbiornikiem, 2 zaworami odcinającymi, miedzianymi przyłączami i uchwytem do KP
A02 Ze zbiornikiem, 2 zaworami odcinającymi, z uniwersalnym odblokowaniem przełączanym (KP17WB), elastycznymi węzłami i skrzynką elektryczną
A04 A01 + KP 17WB + zestaw FSA + przewód zasilający (bez UCGC034)

Kod zasilania

- A Sprężarka 220 V/1 faza/50+60 Hz, wentylator 220 V/1 faza/50+60 Hz
D Sprężarka 400 V/3 fazy/50 Hz, wentylator 400 V/3 fazy/50 Hz
E Sprężarka 400 V/3 fazy/50 Hz, wentylator 230 V/1 faza/50 Hz
G Sprężarka 220 V/1 faza/50 Hz, wentylator 220 V/1 faza/50 Hz

Platforma GS:



Dane wstępne

Dobór automatyki chłodniczej

Model	Typ zaworu rozprężnego	Dysza		Typ filtra osuszacza	Typ wężownika	Typ presostatu	Typ termostatu	Typ zaworu elektromag.		Nr kodowy cewki	Typ reg. obrotów wentyl.	Typ obudowy agregatu
		-10°C	+5°C					-10°C	+5°C			
OP-MCHC004	TS 2/TES 2	0X	0X	DML 052	SGN 6	KP 1/KP 7/KP 17	KP 61/EKC 202			018F6701		118U4620
OP-MCHC006	TS 2/TES 2	00	00	DML 052	SGN 6	KP 1/KP 7/KP 17	KP 61/EKC 202			018F6701		118U4620
OP-MCHC007	TS 2/TES 2	00	00	DML 052	SGN 6	KP 1/KP 7/KP 17	KP 61/EKC 202			018F6701		118U4620
OP-MCHC010	TS 2/TES 2	01	01	DML 052	SGN 6	KP 1/KP 7/KP 17	KP 61/EKC 202			018F6701		118U4620
OP-MCHC012	TS 2/TES 2	01	01	DML 052	SGN 6	KP 1/KP 7/KP 17	KP 61/EKC 202			018F6701		118U4620
OP-MCHC015	TS 2/TES 2	01	01	DML 052	SGN 6	KP 1/KP 7/KP 17	KP 61/EKC 202			018F6701		118U4621
OP-MCHC018	TS 2/TES 2	01	02	DML 052	SGN 6	KP 1/KP 7/KP 17	KP 61/EKC 202			018F6701		118U4621
OP-MCHC021	TS 2/TES 2	01	02	DML 052	SGN 6	KP 1/KP 7/KP 17	KP 61/EKC 202			018F6701		118U4621
OP-MCHC026	TS 2/TES 2	01	02	DML 052	SGN 10	KP 1/KP 7/KP 17	KP 61/EKC 202			018F6701		118U4621
OP-MCHC034	TS 2/TES 2	01	02	DML 052	SGN 10	KP 1/KP 7/KP 17	KP 61/EKC 202			018F6701		118U4621
OP-MCHC038				DML053	SGN 10	KP 1/KP 7/KP 17	KP 61/EKC 202	EVR 3		018F6701	RGE-Z1L4-7DS	118U8030
OP-MCHC048				DML084	SGN 12	KP 1/KP 7/KP 17	KP 61/EKC 202	EVR 3		018F6701	RGE-Z1L4-7DS	118U8031
OP-MCHC054				DML084	SGN 12	KP 1/KP 7/KP 17	KP 61/EKC 202	EVR 3		018F6701	RGE-Z1L4-7DS	118U8031
OP-MCHC060				DML084	SGN 12	KP 1/KP 7/KP 17	KP 61/EKC 202	EVR 3		018F6701	RGE-Z1L4-7DS	118U8031
OP-MCHC068				DML084	SGN 12	KP 1/KP 7/KP 17	KP 61/EKC 202	EVR 6		018F6701	RGE-Z1L4-7DS	118U8031
OP-MCZC086				DML 084	SGN 12	KP 1/KP 7/KP 17	KP 61/EKC 202	EVR 6		018F6701	RGE-Z1L4-7DS	118U8032
OP-MCZC096				DML 084	SGN 12	KP 1/KP 7/KP 17	KP 61/EKC 202	EVR 6		018F6701	RGE-Z1L4-7DS	118U8032
OP-MCZC108				DML 084	SGN 12	KP 1/KP 7/KP 17	KP 61/EKC 202	EVR 6		018F6701	RGE-Z1N4-7DS	118U8032
OP-MCZC121				DML 084	SGN 12	KP 1/KP 7/KP 17	KP 61/EKC 202	EVR 6		018F6701	RGE-Z1N4-7DS	118U8033
OP-MCZC136				DML 084	SGN 12	KP 1/KP 7/KP 17	KP 61/EKC 202	EVR 6		018F6701	RGE-Z1N4-7DS	118U8033
OP-MCZC171				DML 165	SGN 16	KP 1/KP 7/KP 17	KP 61/EKC 202	EVR 10		018F6701	RGE-Z1N4-7DS	118U8033
OP-MGZC215				DML 165	SGN 16	KP 1/KP 7/KP 17	KP 61/EKC 202	EVR 10		018F6701	RGE-Z1Q4-7DS	118U8034
OP-MGZC242				DML 165	SGN 16	KP 1/KP 7/KP 17	KP 61/EKC 202	EVR 10		018F6701	RGE-Z1Q4-7DS	118U8034
OP-MGZC271				DML 165	SGN 16	KP 1/KP 7/KP 17	KP 61/EKC 202	EVR 10		018F6701	RGE-Z1Q4-7DS	118U8034

Podane RGE dotyczą wyłącznie wentylatorów jednofazowych

Agregat skraplający OPTYMA™ R404A/R507 – zaprojektowany specjalnie do zastosowań w wysokich

Warunki testowe	Typ agregatu	Platforma	Wersja A02	Kod zasillania	HP	Skraplacz			Wentylator-skraplacza	Wydajność w [W] przy temp. parowania [°C]						
						Typ	Przepływ powietrza [m³/h]	Obj. wewn. [dm³]	Łopatka wentylatora Ø [mm]	-30	-25	-20	-15	-10	-5	0
	OP-MGZD030	MT	114X5076	G	1½	C3	1.300	1.7	2 × 254	448	713	1.051	1.460	1.941	2.489	3.098
			114X5046	F												
			114X5061	E												
	OP-MGHD038	MP	114X5341	G	1¾	D3	2.800	1.5	2 × 300	1.253	1.645	2.113	2.651	3.258	3.909	4.612
			114X5326	D												
			114X5331	E												
	OP-MGHD048	MP	114X5342	G	2	E3	2.600	2.2	2 × 300	1.662	2.198	2.810	3.492	4.232	5.052	5.298
			114X5327	D												
			114X5332	E												
	OP-MGHD054	MP	114X5343	G	2½	E3	2.600	2.2	2 × 300	1.781	2.378	3.058	3.808	4.622	5.485	6.392
			114X5328	D												
			114X5333	E												
	OP-MGHD060	MP	114X5344	G	3	G3	4.600	2.3	2 × 355	2.117	2.795	3.561	4.423	5.361	6.384	7.477
			114X5329	D												
			114X5334	E												
	OP-MGHD068	MP	114X5330	D	3½	H3	3.600	4.7	2 × 355	2.507	3.301	4.200	5.194	6.269	7.447	8.700
			114X5335	E												
	OP-MGZD086	MT	114X5081	G	4	H3	3.600	4.7	2 × 355	2.319	3.198	4.240	5.453	6.830	8.364	10.046
			114X5052	D												
			114X5067	E												
	OP-MGZD096	MT	114X5053	D	4¾	H3	3.600	4.7	2 × 355	2.370	3.310	4.422	5.717	7.184	8.824	10.620
			114X5068	E												
	OP-MGZD108	MT	114X5054	D	5½	J3	5.400	4.7	2 × 400	3.005	4.113	5.429	6.972	8.740	10.728	12.932
			114X5069	E												
	OP-MGZD121	MT	114X5055	D	6	J3	5.400	4.7	2 × 400	3.387	4.586	6.004	7.650	9.513	11.596	13.876
			114X5070	E												
	OP-MGZD136	MT	114X5056	D	6½	L3	8.600	5.1	2 × 450	4.198	5.630	7.295	9.207	11.361	13.748	16.363
			114X5071	E												
	OP-MGZD171	MT	114X5057	D	8½	M3	8.200	6.8	2 × 450	4.455	6.205	8.259	10.624	13.283	16.211	19.391
			114X5072	E												
OP-MGZD215	MT	114X5115	D	10	N4	9.200	12.3	2 × 500	6.234	8.384	10.937	13.894	17.266	21.026	25.174	
		114X5118	E													
OP-MGZD242	MT	114X5116	D	12	N4	9.200	12.3	2 × 500	7.430	9.881	12.718	15.952	19.558	23.536	27.839	
		114X5119	E													
OP-MGZD271	MT	114X5117	D	13½	U	14.000	14.3	2 × 600	8.239	10.995	14.199	17.878	22.021	26.604	31.624	
		114X5120	E													

Warunki testowe
EN 13215

Temperatura otoczenia
Temperatura gazu na ssaniu
Dochłodzenie w zakresie agregatu skraplającego

Przegrzanie 10K

32°C

RGT20

Stała temp. gazu na ssaniu
32°C
20°C

Dane elektryczne

Model	Sprężarka LRA [A]			Sprężarka MCC [A]					MCC wentylator [A]	
	400 V/ 3 fazy	230 V/ 1 faza	400 V/ 3 fazy	Stycznik	Przełącznik nadmiarowy	230 V/ 1 faza	Stycznik	Przełącznik nadmiarowy	400 V/ 3 fazy	230 V/ 1 faza
OP-MGZD030	20	40	5	CI 6	TI 16C	10	CI 12	TI 16C	-	2x0.32
OP-MGHD038	29.2	56	6.3	CI 9	TI 16C	15	CI 16	TI 16C	2x0.35	2x0.85
OP-MGHD048	29.2	56	6.3	CI 9	TI 16C	16	CI 16	TI 16C	2x0.35	2x0.85
OP-MGHD054	29.2	56	6.4	CI 9	TI 16C	20	CI 20	TI 25C	2x0.35	2x0.85
OP-MGHD060	38.1	61	8.5	CI 12	TI 16C	20	CI 20	TI 25C	2x0.5	2x1.2
OP-MGHD068	38.1	-	9	CI 12	TI 16C	-	-	-	2x0.5	2x1.2
OP-MGZD086	48.5	92	11.5	CI 15	TI 16C	29	CI 30	TI 25C	2x0.5	2x1.2
OP-MGZD096	64	-	12	CI 15	TI 16C	-	-	-	2x0.5	2x1.2
OP-MGZD108	64	-	14	CI 15	TI 16C	-	-	-	2x0.7	2x1.3
OP-MGZD121	80	-	17	CI 20	TI 25C	-	-	-	2x0.7	2x1.3
OP-MGZD136	80	-	19	CI 20	TI 25C	-	-	-	2x1.05	2x1.7
OP-MGZD171	90	-	22	CI 25	TI 25C	-	-	-	2x1.05	2x1.7
OP-MGZD215	105	-	27	CI 37	TI 25C	-	-	-	2x1.2	2x3.4
OP-MGZD242	115	-	30	CI 37	TI 25C	-	-	-	2x1.2	2x3.4
OP-MGZD271	140	-	36	CI 45	TI 25C	-	-	-	2x1.6	2x3.0

temperaturach otoczenia

		Obszar zastosowań przy maks. temperaturze otoczenia (C)	Pobór mocy [W] przy temp. parow.		Pojem. zbiornika [l]	Wymiary [mm]								Waga [kg]	Typ sprężarki
			-10°C	5°C		Rys.	Wys. H [mm]	Szer. W [mm]	Długość D [mm]	Odległ. a [mm]	Odległ. b [mm]	linia ssawna	linia cieczowa		
5	10														
3.765	4.484	48°C: -30°C do -5°C 46°C: -25°C do 0°C	1.344		3	6	392	700	500	300	660	5/8	5/8	56	MTZ18
5.369	6.226		1.550		6	6	442	800	600	400	760	5/8	5/8	60	MPZ038
6.813	7.733		2.000		6	6	442	800	600	400	760	5/8	5/8	64	MPZ048
7.329	8.374		2.290		6	6	442	800	600	400	760	5/8	1/2	65	MPZ054
8.610	9.790		2.700		8	6	555	1.000	700	460	960	5/8	1/2	88	MPZ061
9.959	11.360		3.050		8	6	555	1.000	700	460	960	5/8	1/2	96	MPZ068
11.869	13.829		3.411		8	6	555	1.000	700	460	960	7/8	1/2	107	MTZ51
12.570	14.645		3.763		8	6	555	1.000	700	460	960	7/8	1/2	109	MTZ57
15.346	17.955		4.427		10	6	555	1.000	700	460	960	7/8	1/2	113	MTZ65
16.355	18.997		4.937		10	6	555	1.000	700	460	960	7/8	1/2	115	MTZ73
19.198	22.250		6.426		10	6	671	1.200	800	500	1.160	1 1/8	1/2	133	MTZ81
22.796	26.436		7.565		14	6	671	1.200	800	500	1.160	1 1/8	5/8	158	MTZ100
29.669	34.509		9.657		14	6	759	1.350	820	550	1.315	1 1/8	5/8	196	MTZ125
32.468	37.337		10.757		14	6	759	1.350	820	550	1.315	1 1/8	5/8	199	MTZ144
37.016	42.813		12.319		14	6	975	1.500	870	500	1.460	1 1/8	5/8	230	MTZ160

Wersja

- A00 Bez zaworów i zbiornika do rurki kapilarnej
A01 Ze zbiornikiem, 2 zaworami odcinającymi, miedzianymi przyłączami i uchwytem do KP
A02 Ze zbiornikiem, 2 zaworami odcinającymi, z uniwersalnym odblokowaniem przełączanym (KP17WB), elastycznymi węzłami i skrzynką elektryczną
A04 A01 + KP 17WB + zestaw FSA + przewód zasilający (bez UCGC034)

Kod zasilania

- A Sprężarka 220 V/1 faza/50+60 Hz, wentylator 220 V/1 faza/50+60 Hz
D Sprężarka 400 V/3 fazy/50 Hz, wentylator 400 V/3 fazy/50 Hz
E Sprężarka 400 V/3 fazy/50 Hz, wentylator 230 V/1 faza/50 Hz
G Sprężarka 220 V/1 faza/50 Hz, wentylator 220 V/1 faza/50 Hz

Dobór automatyki chłodniczej

Model	Typ zaworu rozprężnego	Dysza		Typ filtra osuszacza	Typ wziernika	Typ presostatu	Typ termostatu	Typ zaworu elektromag.		Nr kodowy cewki	Typ reg. obrotów wentyl.	Typ obudowy agregatu
		-10°C	+5°C					-10°C	+5°C			
OP-MGZD030	Dobór uzależniony od zastosowania			DML 053	SGN 10	KP 1/KP 7/KP 17	KP 61/EKC 202	EVR 3	EVR 3	018F6701	RGE-Z1L4-7DS	7710017
OP-MGHD038		DML084	SGN12	KP1/KP7/KP17	KP 61/EKC 202	EVR 3	EVR 3	018F6701	RGE-Z1L4-7DS	118U8036		
OP-MGHD048		DML084	SGN12	KP1/KP7/KP17	KP 61/EKC 202	EVR 3	EVR 6	018F6701	RGE-Z1L4-7DS	118U8036		
OP-MGHD054		DML084	SGN12	KP1/KP7/KP17	KP 61/EKC 202	EVR 3	EVR 6	018F6701	RGE-Z1L4-7DS	118U8036		
OP-MGHD060		DML084	SGN12	KP1/KP7/KP17	KP 61/EKC 202	EVR 3	EVR 6	018F6701	RGE-Z1N4-7DS	118U8037		
OP-MGHD068		DML084	SGN 12	KP1/KP7/KP17	KP 61/EKC 202	EVR 6	EVR 6	018F6701	RGE-Z1N4-7DS	118U8037		
OP-MGZD086		DML 084	SGN 12	KP 1/KP 7/KP 17	KP 61/EKC 202	EVR 6	EVR 6	018F6701	RGE-Z1N4-7DS	7710019		
OP-MGZD096		DML 084	SGN 12	KP 1/KP 7/KP 17	KP 61/EKC 202	EVR 6	EVR 10	018F6701	RGE-Z1N4-7DS	7710019		
OP-MGZD108		DML 084	SGN 12	KP 1/KP 7/KP 17	KP 61/EKC 202	EVR 6	EVR 10	018F6701	RGE-Z1N4-7DS	7710019		
OP-MGZD121		DML 084	SGN 12	KP 1/KP 7/KP 17	KP 61/EKC 202	EVR 6	EVR 10	018F6701	RGE-Z1N4-7DS	7710019		
OP-MGZD136		DML 084	SGN 12	KP 1/KP 7/KP 17	KP 61/EKC 202	EVR 6	EVR 10	018F6701	RGE-Z1N4-7DS	7710020		
OP-MGZD171		DML 165	SGN 16	KP 1/KP 7/KP 17	KP 61/EKC 202	EVR 10	EVR 10	018F6701	RGE-Z1N4-7DS	7710020		
OP-MGZD215		DML 165	SGN 16	KP 1/KP 7/KP 17	KP 61/EKC 202	EVR 10	EVR 15	018F6701	RGE-Z1Q4-7DS	118U8034		
OP-MGZD242		DML 165	SGN 16	KP 1/KP 7/KP 17	KP 61/EKC 202	EVR 10	EVR 15	018F6701	RGE-Z1Q4-7DS	118U8034		
OP-MGZD271		DML 165	SGN 16	KP 1/KP 7/KP 17	KP 61/EKC 202	EVR 10	EVR 15	018F6701	RGE-Z1Q4-7DS	7710021		

Podane RGE dotyczą wyłącznie wentylatorów jednofazowych

Agregaty skraplające OPTYMA™ R134a LBP/MBP/HBP

Warunki testowe	Typ agregatu	Platforma	Wersja			Kod zasilania	HP	Skraplacz			Wentylator-skraplacza	Wydajność w [W] przy						
			A00	A01	A04			Typ	Przepływ powietrza [m³/h]	Obj. wewn. [dm³]		Łopatkę wentylatora [mm]	-35	-30	-25	-20	-15	-10
	CECOMAF	OP-UCGC003	TL	114X0104	114X0105	114X0107	G	1/12	BG1	243	0.13	172	37	52	69	91	117	147
		OP-UCGC004	TL	114X0108	114X0109	114X0111	G	1/10	BG1	243	0.13	172	49	67	89	115	146	182
		OP-UCGC005	TL	114X0112	114X0113	114X0115	G	1/8	BG1	243	0.13	172	62	83	108	139	175	217
		OP-UCGC006	FR	114X0200	114X0201	114X0203	G	1/6	BG2	231	0.25	200	74	106	142	185	235	294
		OP-UCGC007	FR	114X0216	114X0217	114X0219	G	1/5	BG2	231	0.25	200	81	114	154	201	257	321
		OP-UCGC008	FR	114X0224	114X0225	114X0227	G	1/5	BG2	231	0.25	200	103	141	186	240	303	376
		OP-UCGC010	FR	114X0232	114X0233	114X0235	G	1/5	BG2	231	0.25	200	103	149	197	254	320	396
		OP-UCGC011	FR	114X0336	114X0337	114X0339	G	1/4	BG3	518	0.31	230	89	168	246	327	414	510
		OP-UCGC012	SC	114X0340	114X0341	114X0343	G	1/3	BG3	518	0.31	230	136	202	285	381	490	610
		OP-UCGC015	SC	114X0448	114X0449	114X0451	G	3/8	BG4	631	0.40	254			348	463	591	731
	OP-UCGC018	SC	114X0556	114X0557	114X0559	G	1/2	BG5	583	0.53	254			404	531	673	833	
	OP-UCGC021	SC	114X0564	114X0565	114X0567	G	3/6	BG5	583	0.53	254			474	622	792	981	
	RGT 20	OP-UCGC026	GS	114X0772	114X0773	114X0775	G	3/4	BG7	990	0.84	300				820	1.040	1.290
OP-UCGC034		GS	114X0780	114X0781	114X0783	G	1	BG7	990	0.84	300				990	1.250	1.500	

Warunki testowe

EN 13125

Temperatura otoczenia

Temperatura gazu na ssaniu

Dochłodzenie w zakresie agregatu skraplającego

RGT 20

Stała temp. gazu na ssaniu

32°C

20°C

CECOMAF

Domowe i podobne

32°C

32°C

Dane elektryczne

Model	Sprężarka LRA	Wentylator MCC
	230 V/1 faza	230 V/1 faza
OP-UCGC003	4.9	0.19
OP-UCGC004	5.1	0.19
OP-UCGC005	5.7	0.19
OP-UCGC006	7.5	0.19
OP-UCGC007	8.1	0.19
OP-UCGC008	8.2	0.19
OP-UCGC010	10	0.19
OP-UCGC011	10	0.25
OP-UCGC012	12.6	0.25
OP-UCGC015	14.8	0.39
OP-UCGC018	18.6	0.39
OP-UCGC021	21.8	0.39
OP-UCGC026	20.2	0.75
OP-UCGC034	25.7	0.75

Dobór automatyki chłodniczej

Model	Typ zaworu rozprężnego	Dysza		
		-25°C	-10°C	+5°C
OP-UCGC003	TN 2/TEN 2	0X	0X	0X
OP-UCGC004	TN 2/TEN 2	0X	0X	0X
OP-UCGC005	TN 2/TEN 2	0X	0X	0X
OP-UCGC006	TN 2/TEN 2	0X	0X	0X
OP-UCGC007	TN 2/TEN 2	0X	0X	00
OP-UCGC008	TS 2/TES 2	0X	0X	00
OP-UCGC010	TS 2/TES 2	0X	0X	00
OP-UCGC011	TS 2/TES 2	0X	0X	00
OP-UCGC012	TS 2/TES 2	0X	00	01
OP-UCGC015	TN 2/TEN 2	0X	00	01
OP-UCGC018	TN 2/TEN 2	0X	01	01
OP-UCGC021	TN 2/TEN 2	00	01	02
OP-UCGC026	TN 2/TEN 2	00	01	02
OP-UCGC034	TN 2/TEN 2	00	01	02

temp. parowania [°C]						Obszar zastosowań przy temperaturze otoczenia 43°C	Pobór mocy [W] przy temp. parow. -25°C	Pojem. zbiornika [l]	Wymiary [mm]							Waga [kg]			Typ sprężarki
									Rys.	Wys. H [mm]	Szer. W [mm]	Długość D [mm]	Odległ. a [mm]	linia ssawna [mm]	linia cieczowa [mm]	A00	A01	A04	
-5	0	5	7.2	10	15	-35°C do +15°C	93	0.8	1	197	289	410	310	6	6	11.4	13.2	14.2	TL3GX
181	220	263	282	309	359	-35°C do +15°C	110	0.8	1	197	289	410	310	6	6	11.4	13.2	14.2	TL4GX
222	269	320	344	377	439	-35°C do +5°C	123	0.8	1	197	289	410	310	6	6	11.4	13.2	14.2	TL5GX
264	317	374	401	436	502	-35°C do +10°C	145	0.8	2	226	304	432	310	10	6	15.1	13.2	17.8	FR6GX
361	437	522	532	617		-35°C do +10°C	159	0.8	2	226	304	432	310	10	6	15.1	16.7	17.8	FR7.5GX
395	478	571	615	674		-35°C do +10°C	181	0.8	2	226	304	432	310	10	6	15.1	16.7	17.8	FR8.5GX
458	550	652	699	762		-35°C do +5°C	207	0.8	2	226	304	432	310	10	6	15.1	16.7	17.8	FR10GX
483	580	688	737	805		-35°C do +5°C	236	1.1	2	256	321	444	325	10	6	15.2	17.6	18.6	FR11GX
616	737	875				-35°C do +5°C	261	1.1	4	256	321	444	325	10	6	15.5	17.9	18.9	SC12GX
741	880	1029	1.095	1.185	1.349	-35°C do +5°C	323	1.1	4	296	331	451	325	10	6	19.8	22.0	22.9	SC15GX
882	1.045	1.220	1.221	1.405	1.603	-35°C do +5°C	367	1.1	4	296	331	473	325	10	6	19.8	23.4	24.2	SC18GX
1.011	1.210	1.432	1.538	1.682	1.962	-35°C do +5°C	437	1.1	4	296	331	513	365	10	6	21.1	23.4	24.2	SC21GX
1.189	1.414	1.652	1.759	1.902	2.160	-35°C do 0°C													
1.575	1.890	2.230	2.390			-20°C do +7.2°C	(-20°) 660	2.4	7	340	430	480	310	12	10	31.5	34.5	36.0	GS26MFX
1.800	2.100	2.450	2.600			-20°C do +7.2°C	(-20°) 700	2.4	7	340	430	480	310	12	10	33.0	36.0	37.5	GS34MFX

Wersja

- A00 Bez zaworów i zbiornika do rurki kapilarnej
- A01 Ze zbiornikiem, 2 zaworami odcinającymi, miedzianymi przyłączami i uchwytem do KP
- A02 Ze zbiornikiem, 2 zaworami odcinającymi, z uniwersalnym odblokowaniem przełączanym (KP17WB), elastycznymi węzłami i skrzynką elektryczną
- A04 A01 + KP 17WB + zestaw FSA + przewód zasilający (bez UCGC034)

Kod zasilania

- A Sprężarka 220 V/1 faza/50+60 Hz, wentylator 220 V/1 faza/50+60 Hz
- D Sprężarka 400 V/3 fazy/50 Hz, wentylator 400 V/3 fazy/50 Hz
- E Sprężarka 400 V/3 fazy/50 Hz, wentylator 230 V/1 faza/50 Hz
- G Sprężarka 220 V/1faza/50 Hz, wentylator 220 V/1 faza/50 Hz

Platforma GS:

Dane wstępne

Typ filtra osuszacza	Typ wziernika	Typ presostatu	Typ termostatu	Typ zaworu elektromag. (bez. cewki)	Nr kodowy cewki	Typ reg. obrotów wentyl.	Typ obudowy agregatu
DML 032	SGN 6	KP1/KP7/KP17	KP61/KP62	EVR 2	018F6701	RGE-Z1L4-7DS	118U4620
DML 032	SGN 6	KP1/KP7/KP17	KP61/KP62	EVR 2	018F6701	RGE-Z1L4-7DS	118U4620
DML 032	SGN 6	KP1/KP7/KP17	KP61/KP62	EVR 2	018F6701	RGE-Z1L4-7DS	118U4620
DML 032	SGN 6	KP1/KP7/KP17	KP61/KP62	EVR 2	018F6701	RGE-Z1L4-7DS	118U4620
DML 032	SGN 6	KP1/KP7/KP17	KP61/KP62	EVR 2	018F6701	RGE-Z1L4-7DS	118U4620
DML 032	SGN 6	KP1/KP7/KP17	KP61/KP62	EVR 2	018F6701	RGE-Z1L4-7DS	118U4620
DML 032	SGN 6	KP1/KP7/KP17	KP61/KP62	EVR 2	018F6701	RGE-Z1L4-7DS	118U4620
DML 032	SGN 6	KP1/KP7/KP17	KP61/KP62	EVR 2	018F6701	RGE-Z1L4-7DS	118U4620
DML 052	SGN 6	KP1/KP7/KP17	KP61/KP62	EVR 3-6 mm	018F6701	RGE-Z1L4-7DS	118U4620
DML 052	SGN 6	KP1/KP7/KP17	KP61/KP62	EVR 3-6 mm	018F6701	RGE-Z1L4-7DS	118U4620
DML 052	SGN 6	KP1/KP7/KP17	KP61/KP62	EVR 3-6 mm	018F6701	RGE-Z1L4-7DS	118U4620
DML 052	SGN 6	KP1/KP7/KP17	KP61/KP62	EVR 3-6 mm	018F6701	RGE-Z1L4-7DS	118U4620
DML 053	SGN 10	KP1/KP7/KP17	KP61/KP62	EVR 3-10 mm	018F6701	RGE-Z1L4-7DS	118U4621
DML 053	SGN 10	KP1/KP7/KP17	KP61/KP62	EVR 3-10 mm	018F6701	RGE-Z1L4-7DS	118U4621

Agregaty skraplające OPTYMA™ R134a – zaprojektowany specjalnie do zastosowań w wysokich temp

	Warunki testowe	Typ agregatu	Platforma	Wersja A02	Kod zasilania	HP	Skraplacz			Wentylator-skraplacza	Wydajność w [W] przy temp.						
							Typ	Przepływ powietrza [m³/h]	Obj. wewn. [dm³]	Łopatka wentylatora Ø [mm]	-15	-10	-5	0	5		
	SH10K	OP-MGZD030	MT	114X5076	G	1½	C3	1300	1.7	2 × 254	892	1.249	1.662	2.133	2.655		
				114X5046	F												
				114X5061	E												
		OP-MGZD038	MT	114X5077	G	1¼	D3	2800	1.5	2 × 300	1.187	1.636	2.168	2.785	3.487		
																114X5047	D
																114X5062	E
		OP-MGZD048	MT	114X5078	G	2	E3	2600	2.2	2 × 300	1.493	2.013	2.650	3.412	4.302		
																114X5048	D
																114X5063	E
		OP-MGZD054	MT	114X5079	G	2½	E3	2600	2.2	2 × 300	1.725	2.330	3.057	3.914	4.898		
																114X5049	D
																114X5064	E
		OP-MGZD060	MT	114X5080	G	3	G3	4600	2.3	2 × 355	2.389	3.094	3.920	4.871	5.951		
																114X5050	D
																114X5065	E
		OP-MGZD068	MT	114X5051	D	3½	H3	3600	4.7	2 × 355	2.826	3.658	4.422	5.393	6.483		
																114X5066	E
																114X5081	G
		OP-MGZD086	MT	114X5052	D	4	H3	3600	4.7	2 × 355	2.955	3.945	5.127	6.513	8.097		
																114X5067	E
114X5053	D																
OP-MGZD096	MT	114X5068	E	4½	H3	3600	4.7	2 × 355	3.534	4.722	6.134	7.773	9.636				
														114X5054	D		
														114X5069	E		
OP-MGZD108	MT	114X5055	D	5½	J3	5400	4.7	2 × 400	3.746	5.025	6.542	8.312	10.336				
														114X5070	E		
														114X5056	D		
OP-MGZD121	MT	114X5071	E	6	J3	5400	4.7	2 × 400	4.424	5.845	7.511	9.424	11.581				
														114X5057	E		
														114X5057	D		
OP-MGZD136	MT	114X5072	E	6½	L3	8600	5.1	2 × 450	5.302	6.934	8.842	11.043	13.536				
														114X5057	D		
														114X5057	E		
OP-MGZD171	MT	114X5115	D	8½	M3	8200	6.8	2 × 450	5.670	7.593	9.876	12.539	15.583				
														114X5118	E		
														114X5116	D		
OP-MGZD215	MT	114X5117	D	10	N4	9200	12.25	2 × 500	7.337	9.725	12.538	15.806	19.529				
														114X5118	E		
														114X5119	E		
OP-MGZD242	MT	114X5117	D	12	N4	9200	12.25	2 × 500	9.072	11.787	14.937	18.538	22.567				
														114X5117	D		
														114X5120	E		
OP-MGZD271	MT	114X5117	D	13½	U	14000	14.2	2 × 600	10.356	13.447	17.074	21.262	26.005				
														114X5120	E		

Warunki testowe EN 13215

Temperatura otoczenia 32°C
 Temperatura gazu na ssaniu
 Dochłodzenie w zakresie agregatu skraplającego

Przegrzanie 10K

32°C

Wersja

- A00 Bez zaworów i zbiornika do rurki kapilarnej
- A01 Ze zbiornikiem, 2 zaworami odcinającymi, miedzionymi przyłączami i uchwytem do KP
- A02 Ze zbiornikiem, 2 zaworami odcinającymi, z uniwersalnym odblokowaniem przełączanym (KP17WB), elastycznymi węzłami i skrzynką elektryczną
- A04 A01 + KP 17WB + zestaw FSA + przewód zasilający (bez UCGC034)

Dane elektryczne

Model	Sprężarka LRA [A]		Sprężarka MCC [A]						Wentylator MCC [A]	
	400 V/ 3 fazy	230 V/ 1 faza	400 V/ 3 fazy	Stycznik	Przełącznik nadmiarowy	230 V/ 1 faza	Stycznik	Przełącznik nadmiarowy	400 V/ 3 fazy	230 V/ 1 faza
OP-MGZD030	20	40	5	CI 6	TI 16C	10	CI 12	TI 16C	-	2x0.32
OP-MGZD038	16	41	6	CI 9	TI 16C	15	CI 16	TI 16C	2x0.35	2x0.85
OP-MGZD048	23	55	7.5	CI 9	TI 16C	16	CI 16	TI 16C	2x0.35	2x0.85
OP-MGZD054	25	70	8	CI 9	TI 16C	20	CI 20	TI 25C	2x0.35	2x0.85
OP-MGZD060	30	70	9	CI 12	TI 16C	20	CI 20	TI 25C	2x0.5	2x1.2
OP-MGZD068	38	-	10	CI 12	TI 16C	-	-	-	2x0.5	2x1.2
OP-MGZD086	48.5	92	11.5	CI 15	TI 16C	29	CI 30	TI 25C	2x0.5	2x1.2
OP-MGZD096	64	-	12	CI 15	TI 16C	-	-	-	2x0.5	2x1.2
OP-MGZD108	64	-	14	CI 15	TI 16C	-	-	-	2x0.7	2x1.3
OP-MGZD121	80	-	17	CI 20	TI 25C	-	-	-	2x0.7	2x1.3
OP-MGZD136	80	-	19	CI 20	TI 25C	-	-	-	2x1.05	2x1.7
OP-MGZD171	90	-	22	CI 25	TI 25C	-	-	-	2x1.05	2x1.7
OP-MGZD215	105	-	27	CI 37	TI 25C	-	-	-	2x1.2	2x3.4
OP-MGZD242	115	-	30	CI 37	TI 25C	-	-	-	2x1.2	2x3.4
OP-MGZD271	140	-	36	CI 45	TI 25C	-	-	-	2x1.6	2x3

Temperaturach otoczenia

Temperatury parowania [°C]			Obszar zastosowań przy temp. otoczenia	Pobór mocy [W] przy temp. parow.		Pojem. zbiornika [l]	Wymiary [mm]						Waga [kg]	Typ sprężarki		
10	15	20		-10°C	5°C		Rys.	Wys. H [mm]	Szer. W [mm]	Długość D [mm]	Odległ. a [mm]	Odległ. b [mm]			linia ssawna [cale]	linia cieczowa [cale]
3.229	3.846	4.504	46°C: -15°C do +15°C 48°C: -15°C do +10°C	793		3	6	392	700	500	300	660	½	¾	56	MTZ18
4.270	5.132	6.070		915		6	6	442	800	600	400	760	½	½	60	MTZ22
5.315	6.449	7.696		1101		6	6	442	800	600	400	760	½	½	64	MTZ28
6.007	7.238	8.571		1341		6	6	442	800	600	400	760	¾	½	65	MTZ32
7.154	8.475	9.914		1619		8	6	555	1000	700	460	960	¾	½	88	MTZ36
7.695	9.029	10.478		1735		8	6	555	1000	700	460	960	¾	½	96	MTZ40
9.880	11.944	13.984		2636		8	6	555	1000	700	460	960	¾	½	107	MTZ51
11.718	14.010	16.840		2378		8	6	555	1000	700	460	960	¾	½	109	MTZ57
12.606	15.116	17.857		2636		10	6	555	1000	700	460	960	¾	½	113	MTZ65
13.975	16.594	19.400		2896		10	6	555	1000	700	460	960	¾	½	115	MTZ73
16.312	19.361	22.682		3907		10	6	671	1200	800	500	1160	1½	½	133	MTZ81
18.995	22.761	26.876		4384		14	6	671	1200	800	500	1160	1½	¾	158	MTZ100
23.700	28.311	33.366		5392		14	6	759	1350	820	550	1315	1½	¾	196	MTZ125
27.005	31.831	36.938		6567		14	6	759	1350	820	550	1315	1½	¾	199	MTZ144
31.278	37.051	43.323		6982		14	6	975	1500	870	500	1460	1½	¾	230	MTZ160

Kod zasilania

- A Sprężarka 220 V/1 faza/50+60 Hz, wentylator 220 V/1 faza/50+60 Hz
- D Sprężarka 400 V/3 fazy/50 Hz, wentylator 400 V/3 fazy/50 Hz
- E Sprężarka 400 V/3 fazy/50 Hz, wentylator 230 V/1 faza/50 Hz
- G Sprężarka 220 V/1 faza/50 Hz, wentylator 220 V/1 faza/50 Hz
- F Sprężarka 400 V/3 fazy/50 Hz, wentylator 400 V/1 faza/50 Hz

Dobór automatyki chłodniczej

Model	Typ zaworu rozprężnego	Dysza		Typ filtra osuszacza	Typ wziernika	Typ presostatu	Typ termostatu	Typ zaworu elektromag.		Nr kodowy cewki	Typ reg. obrotów wentyl.	Typ obudowy agregatu
		-10°C	+5°C					-10°C	+5°C			
OP-MCZC030	Dobór uzależniony od zastosowania			DML053	SGN10	KP1/KP7/KP17	KP 61/EKC202			018F6701	RGE-Z1L4-7DS	118U8030
OP-MCZC038		DML053	SGN10	KP1/KP7/KP17	KP 61/EKC202	EVR3	EVR3	018F6701	RGE-Z1L4-7DS	118U8030		
OP-MCZC048		DML084	SGN12	KP1/KP7/KP17	KP 61/EKC202	EVR3	EVR3	018F6701	RGE-Z1L4-7DS	118U8031		
OP-MCZC054		DML084	SGN12	KP1/KP7/KP17	KP 61/EKC202	EVR3	EVR3	018F6701	RGE-Z1L4-7DS	118U8031		
OP-MCZC060		DML084	SGN12	KP1/KP7/KP17	KP 61/EKC202	EVR3	EVR3	018F6701	RGE-Z1L4-7DS	118U8031		
OP-MCZC068		DML084	SGN12	KP1/KP7/KP17	KP 61/EKC202	EVR3	EVR3	018F6701	RGE-Z1L4-7DS	118U8031		
OP-MCZC086		DML084	SGN12	KP1/KP7/KP17	KP 61/EKC202	EVR3	EVR3	018F6701	RGE-Z1L4-7DS	118U8032		
OP-MCZC096		DML084	SGN12	KP1/KP7/KP17	KP 61/EKC202	EVR3	EVR6	018F6701	RGE-Z1L4-7DS	118U8032		
OP-MCZC108		DML084	SGN12	KP1/KP7/KP17	KP 61/EKC202	EVR3	EVR6	018F6701	RGE-Z1N4-7DS	118U8032		
OP-MCZC121		DML084	SGN12	KP1/KP7/KP17	KP 61/EKC202	EVR3	EVR6	018F6701	REG-Z1N4-7DS	118U8033		
OP-MCZC136		DML084	SGN12	KP1/KP7/KP17	KP 61/EKC202	EVR3	EVR6	018F6701	RGE-Z1N4-7DS	118U8033		
OP-MCZC171		DML165	SGN16	KP1/KP7/KP17	KP 61/EKC202	EVR3	EVR6	018F6701	RGE-Z1N4-7DS	118U8033		
OP-MGZC215		DML165	SGN16	KP1/KP7/KP17	KP 61/EKC202	EVR6	EVR6	018F6701	RGE-Z1Q4-7DS	118U8034		
OP-MGZC242		DML165	SGN16	KP1/KP7/KP17	KP 61/EKC202	EVR6	EVR10	018F6701	RGE-Z1Q4-7DS	118U8034		
OP-MGZC271		DML165	SGN16	KP1/KP7/KP17	KP 61/EKC202	EVR6	EVR10	018F6701	RGE-Z1Q4-7DS	118U8034		

Podane RGE dotyczą wyłącznie wentylatorów jednofazowych

Agregaty skraplające OPTYMA™ R134a

Warunki testowe	Typ agregatu	Platforma	Wersja A02	Kod zasilania	HP	Skraplacz			Wentylator-skraplacza	Wydajność w [W] przy temp.				
						Typ	Przepływ powietrza [m³/h]	Obj. wewn. [dm³]	Łopatka wentylatora Ø [mm]	-15	-10	-5	0	5
	OP-MCZC030	MT	114X5024	G	1½	A4	1.200	1.2	1 × 300	867	1.210	1.604	2.045	2.529
			114X5000	D										
			114X5012	E										
	OP-MCZC038	MT	114X5025	G	1¾	B4	1.750	1.3	1 × 350	1.150	1.580	2.085	2.664	3.312
			114X5001	D										
			114X5013	E										
	OP-MCZC048	MT	114X5026	G	2	C4	2.150	2.3	1 × 350	1.477	1.986	2.606	3.344	4.197
			114X5002	D										
			114X5014	E										
	OP-MCZC054	MT	114X5027	G	2½	C4	2.150	2.3	1 × 350	1.700	2.289	2.995	3.818	4.757
			114X5003	D										
			114X5015	E										
	OP-MCZC060	MT	114X5028	G	3	D4	2.000	3.1	1 × 350	2.322	2.994	3.773	4.658	5.646
			114X5004	D										
			114X5016	E										
	OP-MCZC068	MT	114X5005	D	3½	E4	3.150	2.5	1 × 400	2.736	3.442	4.244	5.147	6.143
114X5017			E											
114X5029			G											
OP-MCZC086	MT	114X5006	D	4	F4	3.300	3.1	1 × 400	2.833	3.770	4.881	6.159	7.601	
		114X5018	E											
		114X5007	D											
OP-MCZC096	MT	114X5019	E	4½	G4	3.150	4.1	1 × 400	3.174	4.232	5.480	6.913	8.527	
		114X5008	D											
		114X5020	E											
OP-MCZC108	MT	114X5009	D	5½	H4	4.300	4.1	1 × 500	3.637	4.863	6.311	7.976	9.860	
		114X5021	E											
		114X5010	D											
OP-MCZC121	MT	114X5022	E	6	J4	6.000	4.4	1 × 500	4.379	5.777	7.410	9.275	11.372	
		114X5011	D											
		114X5023	E											
OP-MCZC136	MT	114X5012	D	6½	K4	6.200	4.7	1 × 500	5.140	6.700	8.513	10.573	12.876	
		114X5013	D											
		114X5014	D											
OP-MCZC171	MT	114X5015	D	8½	L4	5.850	6.3	1 × 500	5.479	7.309	9.465	11.938	14.722	
		114X5016	D											
		114X5017	D											
OP-MGZC215	MT	114X5018	D	10	M4	11.000	7.4	2 × 500	7.169	9.492	12.213	15.352	18.896	
		114X5019	E											
		114X5020	D											
OP-MGZC242	MT	114X5021	E	12	M4	11.000	7.4	2 × 500	8.849	11.467	14.493	17.907	21.692	
		114X5022	E											
		114X5023	D											
OP-MGZC271	MT	114X5024	D	13½	N4	9.200	12.3	2 × 500	10.113	13.087	16.557	20.506	24.933	
		114X5025	E											
		114X5026	E											

Warunki testowe EN 13215

Temperatura otoczenia 32°C
 Temperatura gazu na ssaniu
 Dochłodzenie w zakresie agregatu skraplającego

Przegrzanie 10K

32°C

Wersja

- A00 Bez zaworów i zbiornika do rurki kapilarnej
- A01 Ze zbiornikiem, 2 zaworami odcinającymi, miedzianymi przyłączami i uchwytem do KP
- A02 Ze zbiornikiem, 2 zaworami odcinającymi, z uniwersalnym odblokowaniem przełączanym (KP17WB), elastycznymi węzami i skrzynką elektryczną
- A04 A01 + KP 17WB + zestaw FSA + przewód zasilający (bez UCGC034)

Dane elektryczne

Model	Sprężarka LRA [A]		Sprężarka MCC [A]						Wentylator MCC [A]	
	400 V/ 3 fazy	230 V/ 1 faza	400 V/ 3 fazy	Stycznik	Przełącznik nadmiarowy	230 V/ 1 faza	Stycznik	Przełącznik nadmiarowy	400 V/ 3 fazy	230 V/ 1 faza
OP-MCZC030	20	40	5	Cl 6	Tl 16C	10	Cl 12	Tl 16C	0.35	0.85
OP-MCZC038	16	41	6	Cl 9	Tl 16C	15	Cl 16	Tl 16C	0.5	1.2
OP-MCZC048	23	55	7.5	Cl 9	Tl 16C	16	Cl 16	Tl 16C	0.5	1.2
OP-MCZC054	25	70	8	Cl 9	Tl 16C	20	Cl 20	Tl 25C	0.5	1.2
OP-MCZC060	30	70	9	Cl 12	Tl 16C	20	Cl 20	Tl 25C	0.5	1.2
OP-MCZC068	38	-	10	Cl 12	Tl 16C	-	-	-	0.7	1.3
OP-MCZC086	48.5	92	11.5	Cl 15	Tl 16C	29	Cl 30	Tl 25C	0.7	1.3
OP-MCZC096	64	-	12	Cl 15	Tl 16C	-	-	-	0.7	1.3
OP-MCZC108	64	-	14	Cl 15	Tl 16C	-	-	-	1.2	3.4
OP-MCZC121	80	-	17	Cl 20	Tl 25C	-	-	-	1.2	3.4
OP-MCZC136	80	-	19	Cl 20	Tl 25C	-	-	-	1.2	3.4
OP-MCZC171	90	-	22	Cl 25	Tl 25C	-	-	-	1.2	3.4
OP-MGZC215	105	-	27	Cl 37	Tl 25C	-	-	-	2 x 1.2	2 x 3.4
OP-MGZC242	115	-	30	Cl 37	Tl 25C	-	-	-	2 x 1.2	2 x 3.4
OP-MGZC271	140	-	36	Cl 45	Tl 25C	-	-	-	2 x 1.2	2 x 3.4

parowania [°C]			Obszar zastosowań przy temp. otoczenia	Pobór mocy [W] przy temp. parow.		Pojem. zbiornika [l]	Wymiary [mm]							Waga [kg]	Typ sprężarki	
10	15	20		-10°C	5°C		Rys.	Wys. H [mm]	Szer. W [mm]	Długość D [mm]	Odległ. a [mm]	Odległ. b [mm]	linia ssawna [cale]			linia cieczowa [cale]
3.050	3.603	4.177	46°C: -15°C do +10°C 43°C: -15°C do +15°C	736		3	5	402	500	600	400	465	½	¾	54	MTZ18
4.025	4.799	5.620		909		3	5	451	500	600	400	465	½	¾	56	MTZ22
5.162	6.233	7.391		1.092		6	5	555	630	650	400	595	½	½	64	MTZ28
5.803	6.951	8.176		1.333		6	5	555	630	650	400	595	¾	½	65	MTZ32
6.734	7.898	9.134		1.529		6	5	555	630	650	400	595	¾	½	68	MTZ36
7.233	8.412	9.663		1.687		6	5	605	630	650	400	595	¾	½	72	MTZ40
9.197	10.910	12.728		2.109		8	5	656	755	700	400	720	¾	½	95	MTZ51
10.314	12.234	14.277		2.297		8	5	656	755	700	400	720	¾	½	100	MTZ57
11.953	14.220	16.640		3.056		8	5	656	755	700	400	720	¾	½	113	MTZ65
13.679	16.197	18.865		3.304		10	5	708	900	900	600	865	1½	½	127	MTZ73
15.419	18.153	21.052		4.100		10	5	759	900	900	600	865	1½	½	140	MTZ81
17.810	21.136	24.667		4.224		14	5	759	900	900	600	865	1½	¾	162	MTZ100
22.838	27.178	31.833		5.419		14	6	759	1.350	820	550	1.315	1½	¾	191	MTZ125
25.825	30.206	34.785		6.624		14	6	759	1.350	820	550	1.315	1½	¾	194	MTZ144
29.776	35.038	40.590		7.025		14	6	759	1.350	820	550	1.315	1½	¾	199	MTZ160

Kod zasilania

- A Sprężarka 220 V/1 faza/50+60 Hz, wentylator 220 V/1 faza/50+60 Hz
D Sprężarka 400 V/3 fazy/50 Hz, wentylator 400 V/3 fazy/50 Hz
E Sprężarka 400 V/3 fazy/50 Hz, wentylator 230 V/1 faza/50 Hz
G Sprężarka 220 V/1 faza/50 Hz, wentylator 220 V/1 faza/50 Hz

Dobór automatyki chłodniczej

Model	Typ zaworu rozprężnego	Dysza		Typ filtra osuszacza	Typ wziernika	Typ presostatu	Typ termostatu	Typ zaworu elektromag.		Nr kodowy cewki	Typ reg. obrotów wentyl.	Typ obudowy agregatu
		-10°C	+5°C					-10°C	+5°C			
OP-MCZC030	Dobór uzależniony od zastosowania			DML053	SGN10	KP1/KP7/KP17	KP 61/EKC202			018F6701	RGE-Z1L4-7DS	118U8030
OP-MCZC038		DML053		SGN10	KP1/KP7/KP17	KP 61/EKC202	EVR3	EVR3	018F6701	RGE-Z1L4-7DS	118U8030	
OP-MCZC048		DML084		SGN12	KP1/KP7/KP17	KP 61/EKC202	EVR3	EVR3	018F6701	RGE-Z1L4-7DS	118U8031	
OP-MCZC054		DML084		SGN12	KP1/KP7/KP17	KP 61/EKC202	EVR3	EVR3	018F6701	RGE-Z1L4-7DS	118U8031	
OP-MCZC060		DML084		SGN12	KP1/KP7/KP17	KP 61/EKC202	EVR3	EVR3	018F6701	RGE-Z1L4-7DS	118U8031	
OP-MCZC068		DML084		SGN12	KP1/KP7/KP17	KP 61/EKC202	EVR3	EVR3	018F6701	RGE-Z1L4-7DS	118U8031	
OP-MCZC086		DML084		SGN12	KP1/KP7/KP17	KP 61/EKC202	EVR3	EVR3	018F6701	RGE-Z1L4-7DS	118U8032	
OP-MCZC096		DML084		SGN12	KP1/KP7/KP17	KP 61/EKC202	EVR3	EVR6	018F6701	RGE-Z1L4-7DS	118U8032	
OP-MCZC108		DML084		SGN12	KP1/KP7/KP17	KP 61/EKC202	EVR3	EVR6	018F6701	RGE-Z1N4-7DS	118U8032	
OP-MCZC121		DML084		SGN12	KP1/KP7/KP17	KP 61/EKC202	EVR3	EVR6	018F6701	RGE-Z1N4-7DS	118U8033	
OP-MCZC136		DML084		SGN12	KP1/KP7/KP17	KP 61/EKC202	EVR3	EVR6	018F6701	RGE-Z1N4-7DS	118U8033	
OP-MCZC171		DML165		SGN16	KP1/KP7/KP17	KP 61/EKC202	EVR3	EVR6	018F6701	RGE-Z1N4-7DS	118U8033	
OP-MGZC215		DML165		SGN16	KP1/KP7/KP17	KP 61/EKC202	EVR6	EVR6	018F6701	RGE-Z1Q4-7DS	118U8034	
OP-MGZC242		DML165		SGN16	KP1/KP7/KP17	KP 61/EKC202	EVR6	EVR10	018F6701	RGE-Z1Q4-7DS	118U8034	
OP-MGZC271		DML165		SGN16	KP1/KP7/KP17	KP 61/EKC202	EVR6	EVR10	018F6701	RGE-Z1Q4-7DS	118U8034	

Podane RGE dotyczą wyłącznie wentylatorów jednofazowych

Agregaty skraplające OPTYMA™ R407C

	Warunki testowe	Typ agregatu	Platforma	Wersja A02	Kod zasilania	HP	Skraplacz			Wentylator-skraplacza	Wydajność w [W] przy temp.							
							Typ	Przepływ powietrza [m³/h]	Obj. wewn. [dm³]		Łopatkowa wentylatora Ø [mm]	-15	-10	-5	0			
	SH10K	OP-MCZC030	MT	114X5024	G	1½	A4	1.200	1.2	1 × 300	1.161	1.620	2.134	2.700				
				114X5000	D													
				114X5012	E													
		OP-MCZC038	MT	114X5025	G	114X5001	D	1¾	B4	1.750	1.3	1 × 350	1.683	2.249	2.878	3.658		
																	114X5013	E
																	114X5026	G
		OP-MCZC048	MT	114X5002	D	114X5014	E	2	C4	2.150	2.3	1 × 350	2.149	2.925	3.794	4.746		
																	114X5027	G
																	114X5003	D
		OP-MCZC054	MT	114X5027	G	114X5015	E	2½	C4	2.150	2.3	1 × 350	2.596	3.405	4.296	5.266		
																	114X5028	G
																	114X5004	D
		OP-MCZC060	MT	114X5016	E	114X5005	D	3	D4	2.000	3.1	1 × 350	3.104	3.986	4.946	5.986		
																	114X5017	E
114X5009	D																	
OP-MCZC068	MT	114X5017	E	114X5029	G	3½	E4	3.150	2.5	1 × 400	3.631	4.637	5.742	6.943				
															114X5006	D		
															114X5018	E		
OP-MCZC086	MT	114X5007	D	114X5008	D	4	F4	3.300	3.1	1 × 400	3.965	5.186	6.549	8.048				
															114X5019	E		
															114X5020	E		
OP-MCZC096	MT	114X5020	E	114X5009	D	4½	G4	3.150	4.1	1 × 400	4.366	5.765	7.341	9.089				
															114X5010	D		
															114X5022	E		
OP-MCZC108	MT	114X5011	D	114X5023	E	5½	H4	4.300	4.1	1 × 500	5.342	6.891	8.659	10.646				
															114X5021	E		
															114X5010	D		
OP-MCZC121	MT	114X5011	D	114X5024	E	6	J4	6.000	4.4	1 × 500	6.068	7.882	9.942	12.250				
															114X5010	D		
															114X5022	E		
OP-MCZC136	MT	114X5011	D	114X5025	E	6½	K4	6.200	4.7	1 × 500	6.821	8.863	11.143	13.650				
															114X5011	D		
															114X5023	E		
OP-MCZC171	MT	114X5023	E	114X5024	E	8½	L4	5.850	6.3	1 × 500	7.433	9.892	12.645	15.692				
															114X5024	E		
															114X5024	E		
OP-MGZC215	MT	114X5024	E	114X5025	E	10	M4	11.000	7.4	2 × 500	11.007	14.191	17.757	21.713				
															114X5025	E		
															114X5025	E		
OP-MGZC242	MT	114X5025	E	114X5026	E	12	M4	11.000	7.4	2 × 500	12.089	15.606	19.542	23.895				
															114X5026	E		
															114X5026	E		
OP-MGZC271	MT	114X5026	E	114X5027	E	13½	N4	9.200	12.3	2 × 500	14.508	18.346	22.647	27.411				
															114X5027	E		

Warunki testowe EN 13215

Temperatura otoczenia
Temperatura gazu na ssaniu
Dochłodzenie w zakresie agregatu skraplającego

Przegrzanie 10K

32°C

Wersja A02

Ze zbiornikiem, 2 zaworami odcinającymi, z uniwersalnym odblokowaniem przełączanym (KP17WB), elastycznymi węzłami i skrzynką elektryczną

Dane elektryczne

Model	Sprężarka LRA [A]		Sprężarka MCC [A]						Wentylator MCC [A]	
	400 V / 3 fazy	230 V / 1 faza	400 V / 3 fazy	Stycznik	Przełącznik nadmiarowy	230 V / 1 faza	Stycznik	Przełącznik nadmiarowy	400 V / 3 fazy	230 V / 1 faza
OP-MCZC030	20	40	5	CI 6	TI 16C	10	CI 12	TI 16C	0.35	0.85
OP-MCZC038	16	41	6	CI 9	TI 16C	15	CI 16	TI 16C	0.5	1.2
OP-MCZC048	23	55	7.5	CI 9	TI 16C	16	CI 16	TI 16C	0.5	1.2
OP-MCZC054	25	70	8	CI 9	TI 16C	20	CI 20	TI 25C	0.5	1.2
OP-MCZC060	30	70	9	CI 12	TI 16C	20	CI 20	TI 25C	0.5	1.2
OP-MCZC068	38	-	10	CI 12	TI 16C	-	-	-	0.7	1.3
OP-MCZC086	48.5	92	11.5	CI 15	TI 16C	29	CI 30	TI 25C	0.7	1.3
OP-MCZC096	64	-	12	CI 15	TI 16C	-	-	-	0.7	1.3
OP-MCZC108	64	-	14	CI 15	TI 16C	-	-	-	1.2	3.4
OP-MCZC121	80	-	17	CI 20	TI 25C	-	-	-	1.2	3.4
OP-MCZC136	80	-	19	CI 20	TI 25C	-	-	-	1.2	3.4
OP-MCZC171	90	-	22	CI 25	TI 25C	-	-	-	1.2	3.4
OP-MGZC215	105	-	27	CI 37	TI 25C	-	-	-	2 x 1.2	2 x 3.4
OP-MGZC242	115	-	30	CI 37	TI 25C	-	-	-	2 x 1.2	2 x 3.4
OP-MGZC271	140	-	36	CI 45	TI 25C	-	-	-	2 x 1.2	2 x 3.4

parowania [°C]		Obszar zastosowań przy temp. otoczenia		Pobór mocy [W] przy temp. parow.		Pojem. zbiornika [l]	Wymiary [mm]								Waga [kg]	Typ sprężarki	
5	10	38°C		-10°C	5°C		Rys.	Wys. H [mm]	Szer. W [mm]	Długość D [mm]	Odległ. a [mm]	Odległ. b [mm]	linia ssawna [cale]	linia cieczowa [cale]			
3.305	3.945	-10°C do +10°C		1.007		3	5	408	500	600	400	465	½	¾	54	MTZ18	
4.309	5.093				1.367		3	5	451	500	620	400	465	½	¾	56	MTZ22
5.781	6.879				1.639		6	5	555	630	650	400	595	½	½	64	MTZ28
6.294	7.376				1.878		6	5	555	630	650	400	595	¾	½	65	MTZ32
7.070	8.198				2.248		6	5	555	630	650	400	595	¾	½	68	MTZ36
8.214	9.550				2.662		6	5	605	630	650	400	595	¾	½	72	MTZ40
9.662	11.380				2.869		8	5	656	755	700	400	720	7/8	½	95	MTZ51
10.981	12.996				3.061		8	5	656	755	700	400	720	7/8	½	100	MTZ57
12.827	15.180				4.047		8	5	656	755	700	400	720	7/8	½	113	MTZ65
14.764	17.469				4.659		10	5	708	900	900	600	865	1 1/8	½	127	MTZ73
16.349	19.224				5.387		10	5	759	900	900	600	865	1 1/8	½	140	MTZ81
18.969	22.458				6.209		14	5	759	900	900	600	865	1 1/8	¾	162	MTZ100
25.991	30.572				8.375		14	6	759	1.350	820	550	1.315	1 1/8	¾	191	MTZ125
28.625	33.732				9.399		14	6	759	1.350	820	550	1.315	1 1/8	¾	194	MTZ144
32.558	38.075				10.678		14	6	759	1.350	820	550	1.315	1 1/8	¾	199	MTZ160

Kod zasilania

D Sprężarka 400 V/3 fazy/50 Hz, wentylator 400 V/3 fazy/50 Hz

E Sprężarka 400 V/3 fazy/50 Hz, wentylator 230 V/1 faza/50 Hz

G Sprężarka 220 V/1 faza/50 Hz, wentylator 220 V/1 faza/50 Hz

Dobór automatyki chłodniczej

Model	Typ zaworu rozprężnego	Dysza		Typ filtra osuszacza	Typ wziernika	Typ presostatu	Typ termostatu	Typ zaworu elektromag.		Nr kodowy cewki	Typ reg. obrotów wentyl.	Typ obudowy agregatu
		-10°C	+5°C					-10°C	+5°C			
OP-MCZC030	Dobór uzależniony od zastosowania			DML053	SGN10	KP1/KP7/KP17	KP 61/EKC 202			018F6701	RGE-Z1L4-7DS	118U8030
OP-MCZC038				DML053	SGN10	KP1/KP7/KP17	KP 61/EKC 202	EVR 3	EVR 3	018F6701	RGE-Z1L4-7DS	118U8030
OP-MCZC048				DML084	SGN12	KP1/KP7/KP17	KP 61/EKC 202	EVR 3	EVR 3	018F6701	RGE-Z1L4-7DS	118U8031
OP-MCZC054				DML084	SGN12	KP1/KP7/KP17	KP 61/EKC 202	EVR 3	EVR 3	018F6701	RGE-Z1L4-7DS	118U8031
OP-MCZC060				DML084	SGN12	KP1/KP7/KP17	KP 61/EKC 202	EVR 3	EVR 3	018F6701	RGE-Z1L4-7DS	118U8031
OP-MCZC068				DML084	SGN12	KP1/KP7/KP17	KP 61/EKC 202	EVR 3	EVR 6	018F6701	RGE-Z1L4-7DS	118U8031
OP-MCZC086				DML084	SGN12	KP1/KP7/KP17	KP 61/EKC 202	EVR 3	EVR 6	018F6701	RGE-Z1L4-7DS	118U8032
OP-MCZC096				DML084	SGN12	KP1/KP7/KP17	KP 61/EKC 202	EVR 3	EVR 6	018F6701	RGE-Z1L4-7DS	118U8032
OP-MCZC108				DML084	SGN12	KP1/KP7/KP17	KP 61/EKC 202	EVR 3	EVR 6	018F6701	RGE-Z1N4-7DS	118U8032
OP-MCZC121				DML084	SGN12	KP1/KP7/KP17	KP 61/EKC 202	EVR 3	EVR 6	018F6701	REG-Z1N4-7DS	118U8033
OP-MCZC136				DML084	SGN12	KP1/KP7/KP17	KP 61/EKC 202	EVR 3	EVR 6	018F6701	RGE-Z1N4-7DS	118U8033
OP-MCZC171				DML165	SGN16	KP1/KP7/KP17	KP 61/EKC 202	EVR 6	EVR 6	018F6701	RGE-Z1N4-7DS	118U8033
OP-MGZC215				DML165	SGN16	KP1/KP7/KP17	KP 61/EKC 202	EVR 6	EVR 10	018F6701	RGE-Z1Q4-7DS	118U8034
OP-MGZC242				DML165	SGN16	KP1/KP7/KP17	KP 61/EKC 202	EVR 6	EVR 10	018F6701	RGE-Z1Q4-7DS	118U8034
OP-MGZC271				DML165	SGN16	KP1/KP7/KP17	KP 61/EKC 202	EVR 6	EVR 10	018F6701	RGE-Z1Q4-7DS	118U8034

Podane RGE dotyczą wyłącznie wentylatorów jednofazowych

Wymiary

1

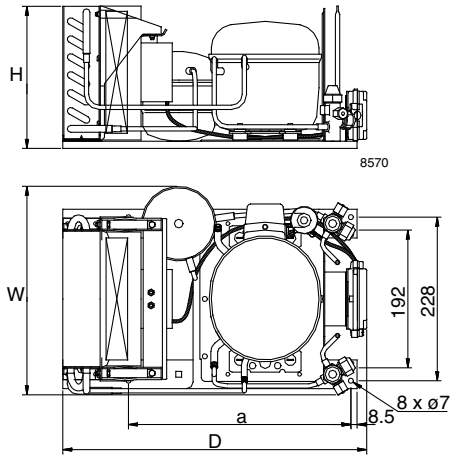

2

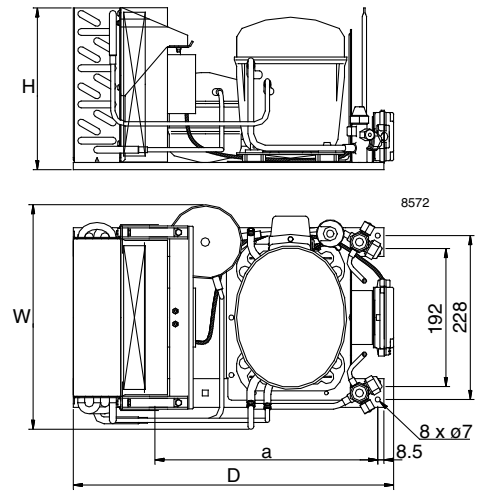

3

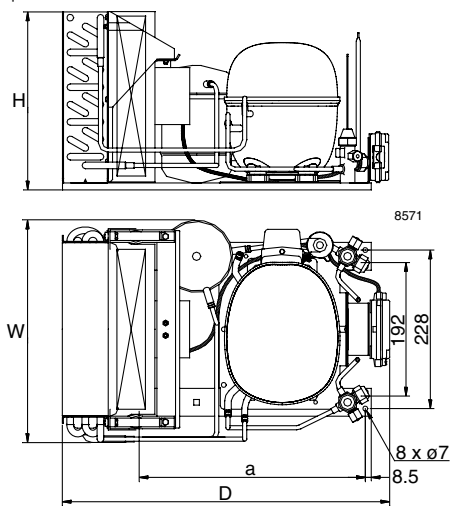

4

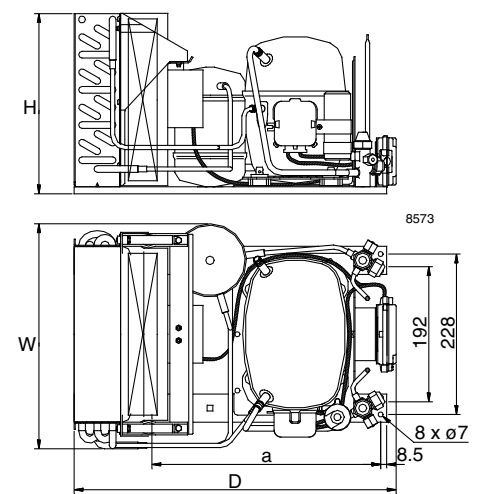

Wymiary

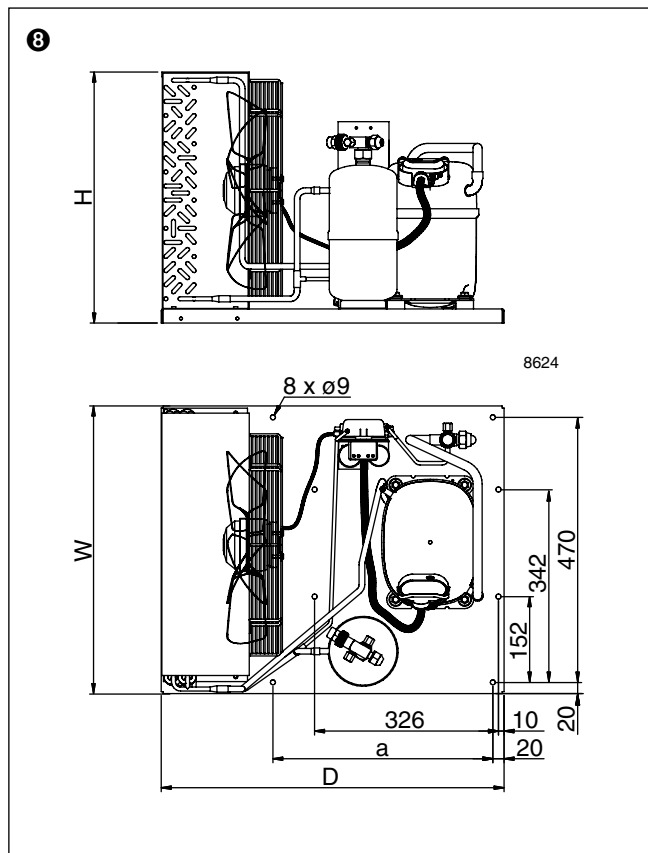
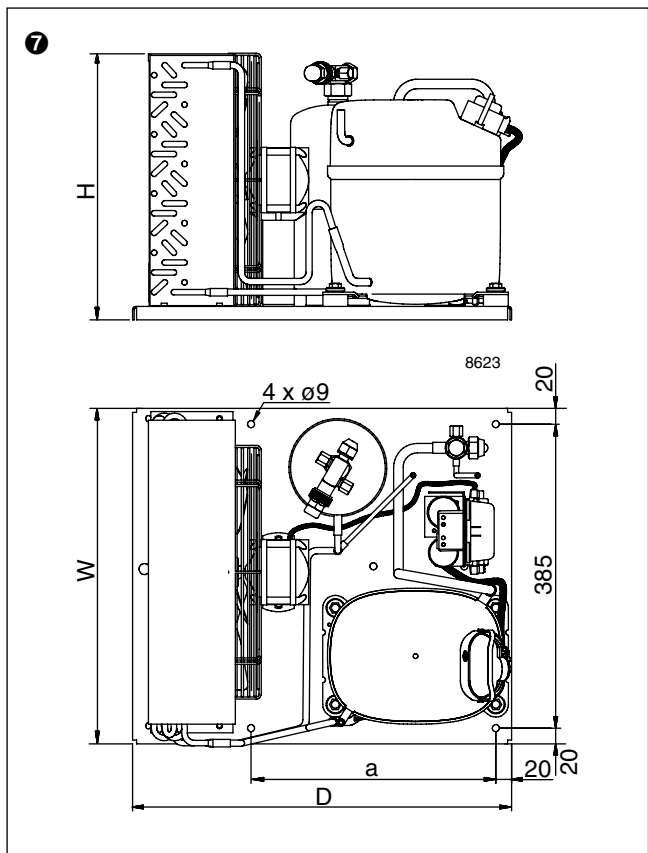
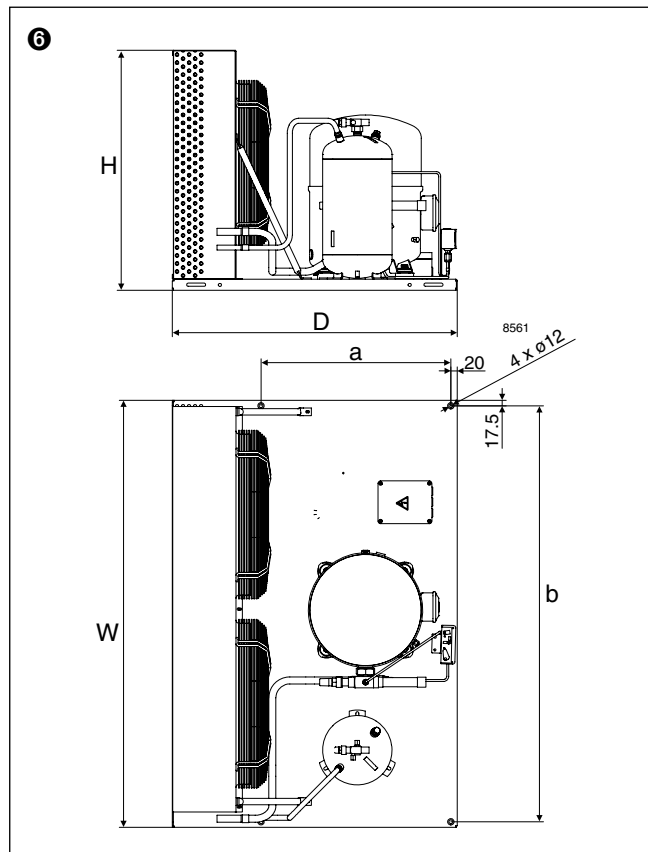
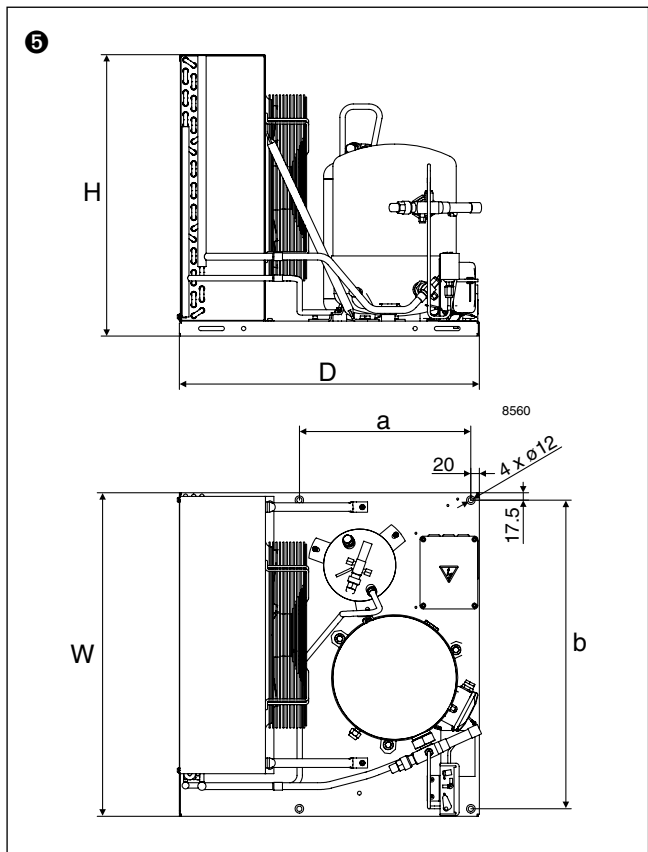

Agregaty skraplające OPTYMA™: optymalne zastosowania i optymalny serwis

OPTYMA™ to nowa nazwa najszerzej na rynku oferty agregatów skraplających. Nowo zaprojektowane rozwiązanie OPTYMA™, z jednym lub dwoma wentylatorami oraz z nową serią sprężarek niskotemperaturowych NTZ, spełnia w sposób optymalny wymagania klientów. Optymalny zakres stosowania został osiągnięty również dzięki poprawieniu współczynnika COP, obniżeniu poziomu hałasu i zużycia energii elektrycznej oraz znacznemu poszerzeniu możliwości zastosowań, zarówno dla prostych, jak i bardziej rozbudowanych układów chłodniczych.

Dodatkowo oferujemy naszym klientom wsparcie techniczne i doradztwo. Lokalne oddziały Danfoss oraz szeroka sieć wyspecjalizowanych partnerów handlowych zapewniają pomoc i są do Państwa dyspozycji. Wierzymy, że „optymalny serwis” spełni Państwa oczekiwania.

Zalety

- Przeprojektowane, wysoce efektywne skraplacze umożliwiają pracę przy wyższych temperaturach otoczenia.
- Zastosowanie wysokiej jakości komponentów zapewniających długą żywotność urządzenia i mniejsze koszty serwisowania.
- Krótki czas montażu dzięki fabrycznie przygotowanym i sprawdzonym przyłączom.
- Nowe uchwyty w podstawie agregatu umożliwiające łatwy transport i instalację.
- Podstawa montażowa zaprojektowana w sposób umożliwiający zawieszenie na ścianie.

- Rozwiązanie umożliwiające późniejszą rozbudowę o dodatkowe wyposażenie, takie jak: regulator obrotów wentylatora, oddzielnik oleju, presostaty lub osłona zewnętrzna.
- Łatwy dostęp do wszystkich komponentów agregatu umożliwiający prostą i sprawną obsługę.
- Wymiary dostosowane do wymogów aplikacji.
- Zapewnione wsparcie techniczne.

Fakty

- Praca z czynnikami chłodniczymi z grupy HFC R134a, R404A i R507 (MCZC i MGZC mogą pracować z czynnikiem R407C),
- Szeroki zakres wydajności: od 50 do 40 000 W R404A,
- Podwyższony współczynnik COP,
- 100% agregatów poddawanych fabrycznie testowi szczelności.

Charakterystyka

- Nowe sprężarki o wysokiej sprawności (MBP + LBP)
- Niskie zużycie energii elektrycznej,
- Szeroki zakres zastosowań,
- Części stalowe malowane proszkowo,
- Standardowo podgrzewany karter sprężarki (opcjonalnie dla mniejszych modeli),
- Standardowo dostarczane zawory serwisowe z przyłączami,
- Zawory odcinające/wyprowadzone króćce zapewniające łatwy montaż.

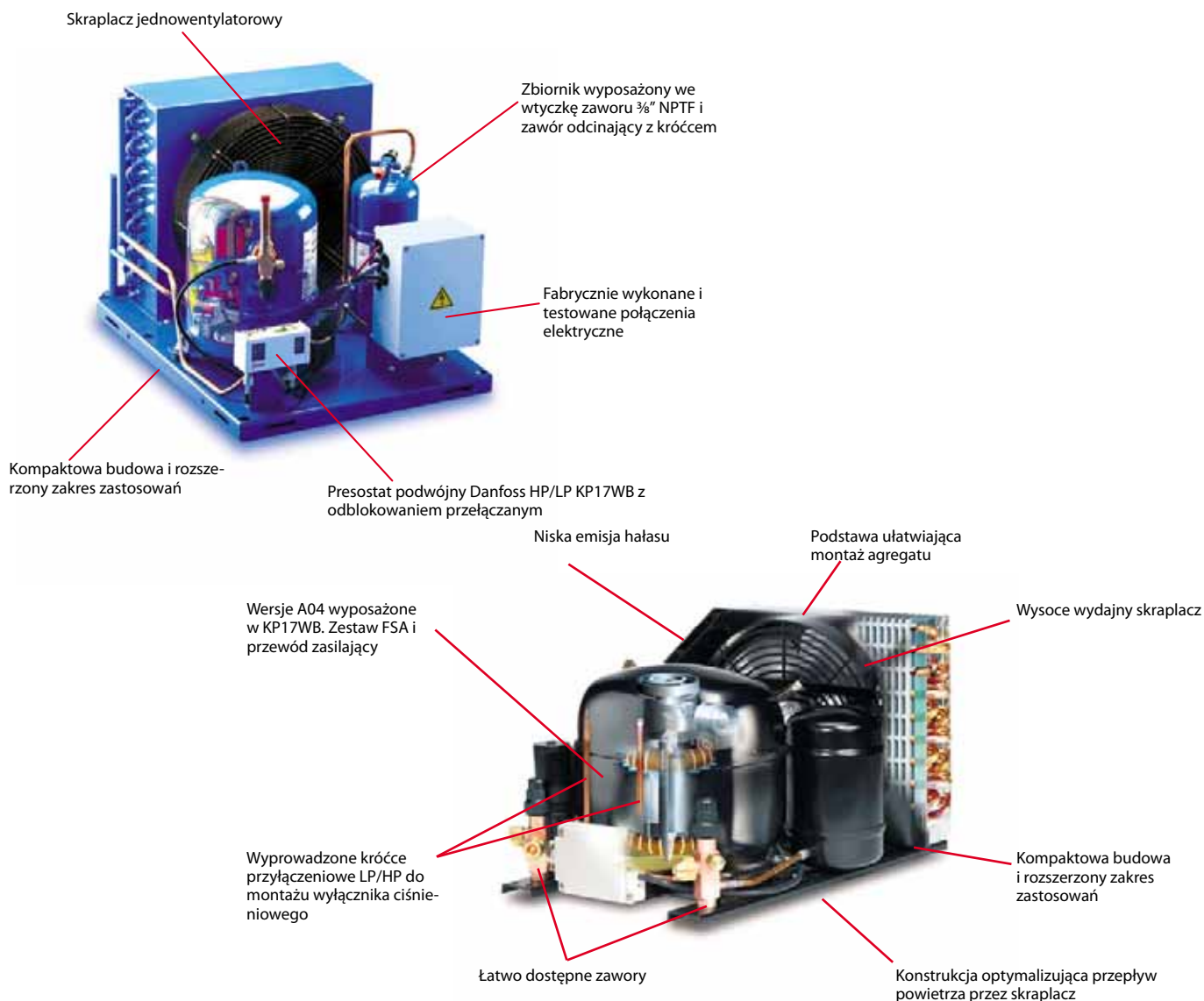

System oznaczania w standardowym programie OPTYMA™

(dodatkowe częstotliwości itp.: prosimy skontaktować się z lokalnym sprzedawcą hurtowym).

1. Zastosowanie
2. Konstrukcja agregatu
3. Rodzaj czynnika chłodniczego
4. Typ skraplacza
5. Pojemność skokowa
6. Typ sprężarki
7. Wersja wyposażenia
8. Kod zasilania

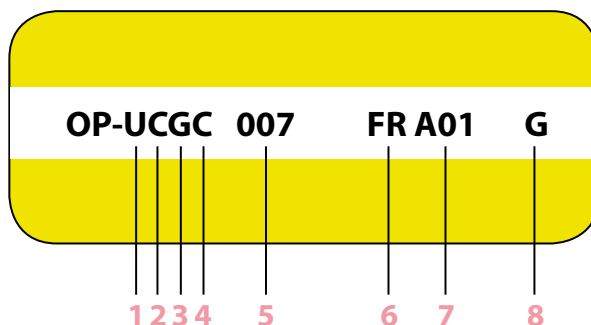

Niskotemperaturowe	L
Średniotemperaturowe	M
Nisko/średnio/wysokotemp.	U

C: Skraplacz powietrzny jednowentylatorowy, sprężarka hermetyczna
G: Skraplacz powietrzny dwuwentylatorowy, sprężarka hermetyczna

R134a	G
R404A/R507	H
R407C	C
R22	M
R404A/R134a/R507/R407C	Z

Standardowy	C
Powiększony	D

012 = 12 cm ³ 007 = 7.5 cm ³

TL	FR	NL	SC	GS	NT	MT	MP
----	----	----	----	----	----	----	----

A00 =	Bez zaworów i zbiornika do rurek kapilarnych
A01 =	Zestaw podstawowy, przyłącze i uchwyt do montażu KP
A02 =	Ze zbiornikiem, zaworami odcinającymi, uniwersalnym wyłącznikiem ciśnieniowym (KP 17WB), elastycznymi węzłami i skrzynką elektryczną
A04 =	A01 + KP17WB + zestaw FSA+ przewód zasilający

A: Sprężarka 220 V/1 faza / 50+60 Hz, wentylator 220 V / 1 faza/50+60 Hz
G: Sprężarka 220 V / 1 faza / 50 Hz wentylator 220 V / 1 faza/ 50 Hz
D: Sprężarka 400 V / 3 fazy / 50 Hz wentylator 400 V / 3 fazy / 50 Hz
E: Sprężarka 400 V / 3 fazy / 50 Hz wentylator 230 V / 1 faza / 50 Hz
F: Sprężarka 400 V / 3 fazy / 50 Hz, wentylator 400 V / 1 faza / 50 Hz

Inne produkty

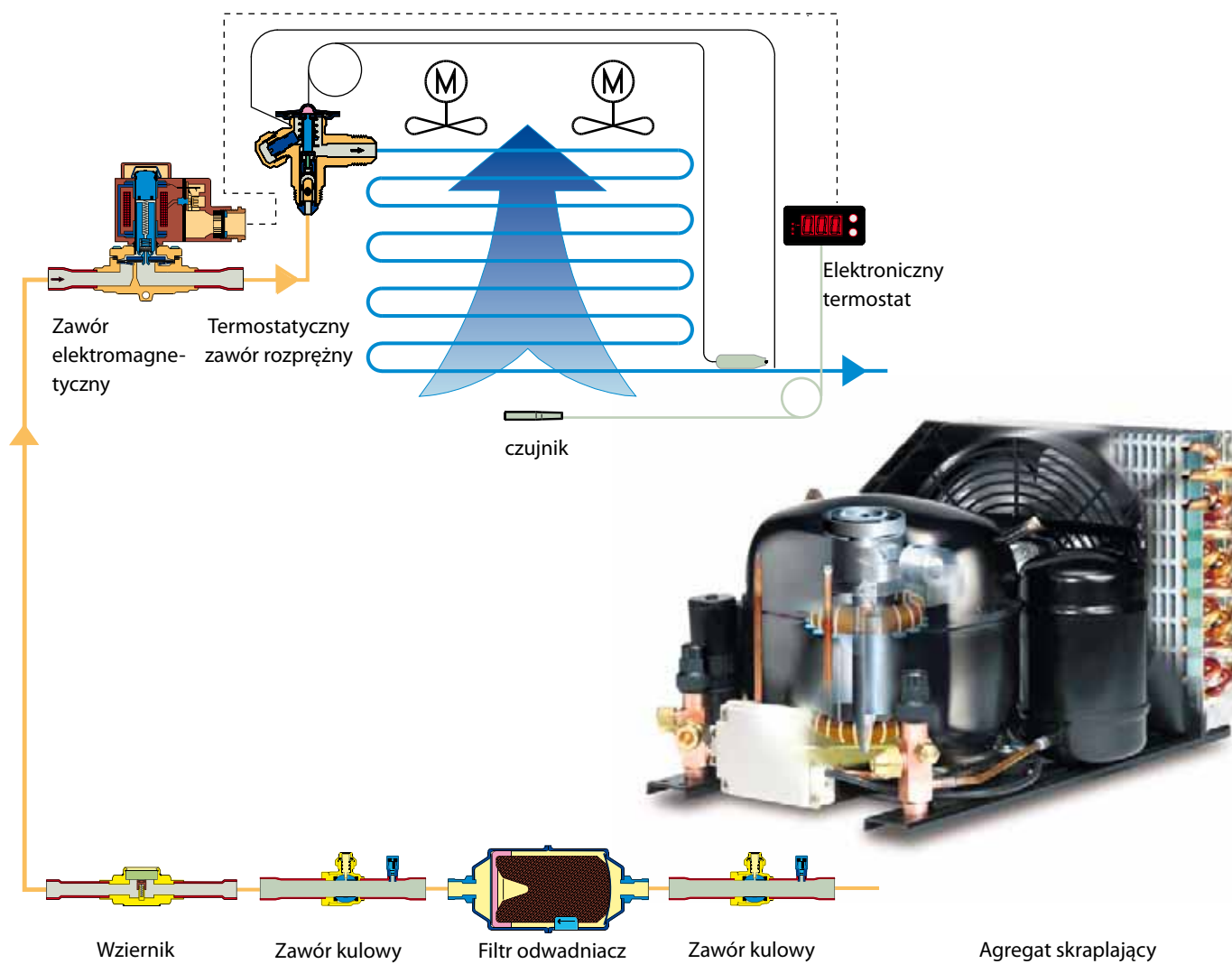



Wersje OPTYMA™ A01



Wersje OPTYMA™ A02



Wersje OPTYMA™ A04



Agregaty skraplające
OPTYMA PLUS™



Agregaty zaprojektowane
wg indywidualnych
wymogów klienta



Obudowy agregatów
OPTYMA™

Program agregatów skraplających Danfoss

OPTYMA™ to największa dostępna gama hermetycznych agregatów skraplających wykorzystujących sprężarki Danfoss. W zakładach produkcyjnych Danfoss stosowane są najnowocześniejsze procesy, a każdy produkt jest dokładnie testowany pod kątem zgodności z najsurowszymi normami.

Jeśli program OPTYMA™ nie zawiera agregatu skraplającego, jakiego Państwo poszukują, i/lub taki agregat nie został wspomniany w niniejszej ulotce, Danfoss może zaoferować konstrukcje tworzone według zaleceń klienta. Partnerzy handlowi oraz lokalny zespół Danfoss są do Państwa dyspozycji i chętnie służą pomocą przy doborze urządzeń. Zrobimy wszystko, aby w pełni zaspokoić Państwa oczekiwania.



Szczegółowe informacje można uzyskać, korzystając z naszego oprogramowania RS+™3